



# TRUCK & BUS TYRES

## TECHNICAL DATA & REGROOVING

# THE COMMERCIAL VEHICLE TYRES SPECIALIST

**Prometeon Tyre Group** is the only company entirely focused on the **commercial tyre sector**, including the transportation of goods and people, agriculture, and off-road.

Prometeon offers a **multi-level, multi-brand portfolio**, which includes its own brands: PROMETEON, ANTEO, ERACLE, and TEGRYS, as well as the brands PIRELLI and FORMULA, used under license.

Prometeon was officially established in 2017 as a spin-off from the commercial tyres division of Pirelli Tyre company and can count on **over 100 years of experience** in the design, development, and manufacturing of tyres. The Group is deeply **committed to innovation through the introduction of new technologies and a path towards constant, sustainable growth**. As from 2017 each and every PIRELLI Branded Tyre for Truck, Bus, Agriculture and OTR have been designed, manufacturer and distributed by Prometeon Tyre Group under exclusive license.

The commitment to excellence is the foundation of Prometeon's offering, resulting in continuous research and an ongoing effort to identify and meet the real needs of the market.

The flagship product of the company's offering is the **Serie02**, the first full range completely designed in Prometeon R&D Centres. Launched in 2022 with PIRELLI brand and Prometeon Engineered marking, now only **PROMETEON branded**. It embodies the company's commitment to further strengthening its identity as an independent player focused exclusively on the commercial tyre sector. It is specifically designed to maximize **performance, safety, quality, and sustainability**.



2022



2024



SERIE  
02

YOU KNOW  
THE TYRE.

NOW MEET  
THE BRAND.











# KEY FIGURES (2025 DATA)



# INDEX

RANGE OVERVIEW	pag.	6
SERIE 02 UNIQUE INNOVATIVE TECHNOLOGICAL PLATFORM	pag.	9
ABBREVIATIONS AND SYMBOLS EXPLANATION	pag.	10
PRODUCT RANGE OVERVIEW	pag.	11
TYRE MARKINGS	pag.	20
TECHNICAL TABLES LEGEND	pag.	21
EU TYRE LABELLING REGULATION	pag.	22
<hr/>		
TYRE LABELLING TABLE	pag.	24
DIMENSIONAL AND LOAD/PRESSURE TABLES	pag.	32
LOAD LIMITS AT VARIOUS SPEEDS	pag.	47
LOAD AND SPEED TABLES	pag.	48
RADIO FREQUENCY IDENTIFICATION DEVICE	pag.	49
INFLATION PRESSURE	pag.	50
STORAGE	pag.	51
<hr/>		
REGROOVING	pag.	52

# RANGE OVERVIEW

		PREMIUM	PERFORMANCE
ON	 <b>FUEL EFFICIENCY</b> Product designed to provide low fuel consumption and total cost of ownership optimization. The best balance between mileage and fuel efficiency is found in long distance and highway routes.	H02 PROFUEL H02 PRO TRAILER	
	 <b>VERSATILITY</b> Product designed to guarantee high mileage in any condition of usage and good resistance to highly abrasive surfaces. High level of safety on all roads and in all seasons.	R02 PROFUEL R02 PROWAY R02 PRO TRAILER	ITINERIS S ITINERIS D ITINERIS T
	 <b>WINTER</b> Products designed for use under critical weather conditions, snow and ice.	FW:01 TW:01	
	 <b>COACH</b> Specifically designed for comfort and safety in passenger transport, over medium and long distances.	C02 COACH	
	 <b>URBAN</b> For urban passenger vehicles in stop & go traffic conditions, low average speed, continuous changes in road surfaces (asphalt, concrete, cobblestones).	U02 URBAN-e MULTIAXLE	MC88 III
ON-OFF	 <b>CONSTRUCTION</b> For mixed use on roads, on construction sites and under aggressive tread-wear condition.	G02 ECO G02 PRO MULTIAXLE	G:01 II MG:01 G88
	 <b>QUARRY &amp; MINE</b> Products designed for use mainly on construction sites, in quarries and mining operations with highly aggressive tread-wear conditions.	TQ:01 ROCK	
	 <b>SPECIAL USE</b> Products designed for use in demanding off-the-road situations on various types of surface (asphalt, track, muddy or grassy terrain, sand). Typical use off-the-road competition vehicles and civil protection department.	S02 PISTA PS22	

# RANGE OVERVIEW

OR is a trademark of Prometeon Tyre Group.

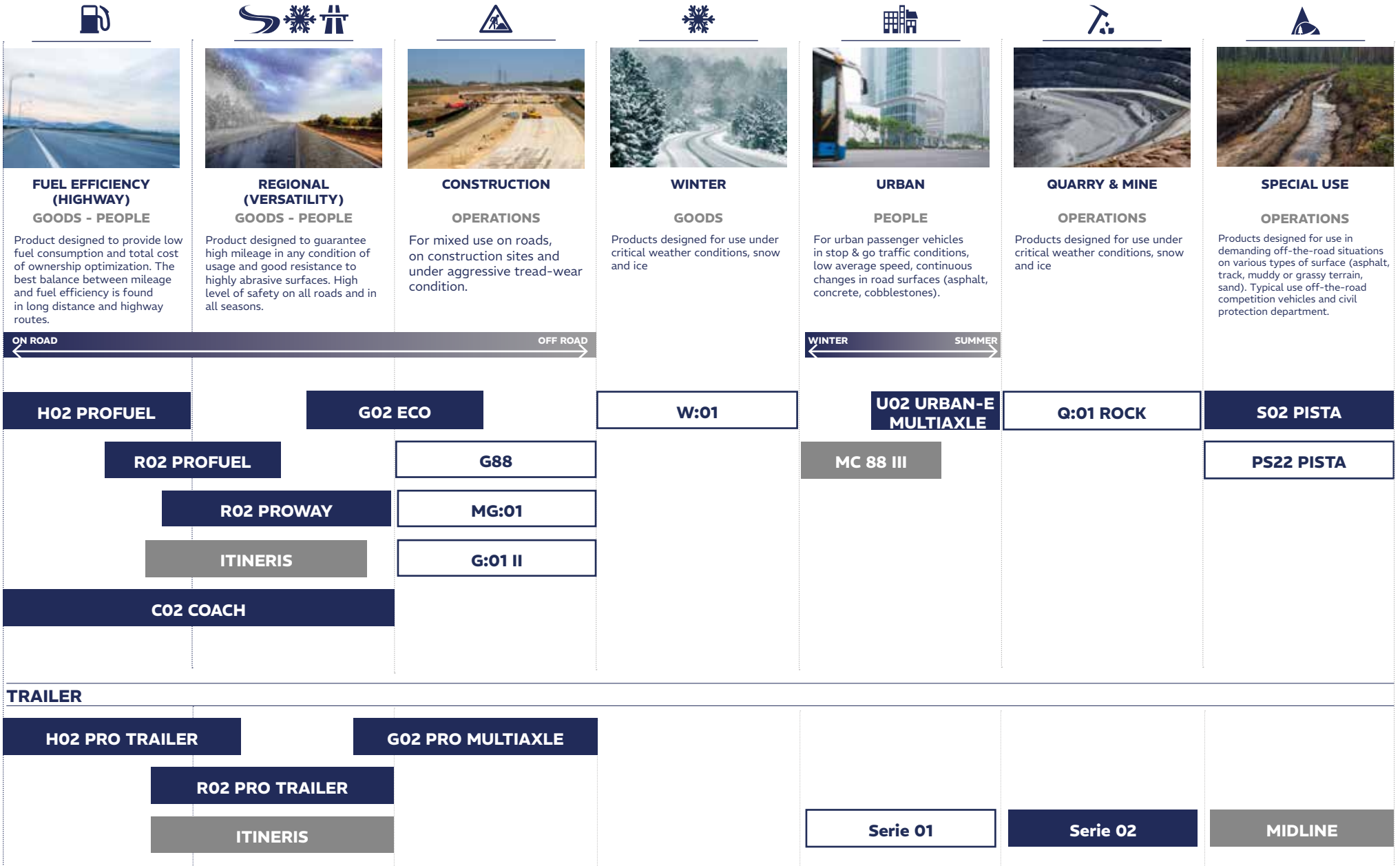

# RANGE OVERVIEW

## STEER / MULTIAXLE

## DRIVE

## TRAILER

ON

**FUEL EFFICIENCY**

**VERSATILITY**

**WINTER**

**COACH**

**URBAN**

**H02 PROFUEL STEER**

**H02 PROFUEL DRIVE**

**H02 PRO TRAILER**

**R02 PROFUEL STEER 22.5"**

**R02 PROFUEL STEER 17.5" & 19.5"**

**R02 PROWAY STEER**

**ITINERIS S**

**R02 PROFUEL DRIVE 22.5"**

**R02 PROFUEL DRIVE 17.5" & 19.5"**

**R02 PROWAY DRIVE**

**ITINERIS D**

**R02 PRO TRAILER 22.5"**

**R02 PRO TRAILER 17.5" & 19.5"**

**ITINERIS T**

**FW:01**

**TW:01**

**C02 COACH MULTIAXLE**

**C02 COACH DRIVE**

**U02 URBAN-e MULTIAXLE**

**MC88 III AMARANTO**

ON-OFF

**CONSTRUCTION**

**QUARRY & MINE**

**SPECIAL USE**

**G02 ECO MULTIAXLE**

**G02 PRO MULTIAXLE**

**FG:01 II**

**FG88**

**MG:01**

**G02 ECO DRIVE**

**TG:01 II**

**TG88**

**TQ:01 ROCK**

**S02 PISTA**

**PS22**

# SERIE 02 UNIQUE INNOVATIVE TECHNOLOGICAL PLATFORM



Highly innovative PRO Grip Environment Approach compound formulated to improve the **tyre efficiency** and **safe performance** while **reducing environmental impact**.



The Super High Tensile Belt cord allows high flexibility and prevention of corrosion propagation for:

- superior **integrity**
- high **resistance** to aging



The innovative Low Energy Dissipation Belts configuration ensures tyre weight optimization and lower energy dissipation enabling **low rolling resistance** generation.

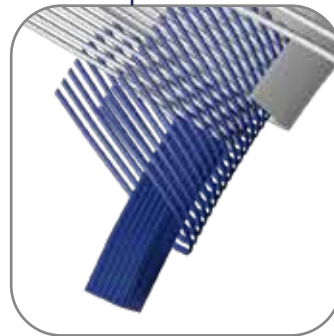
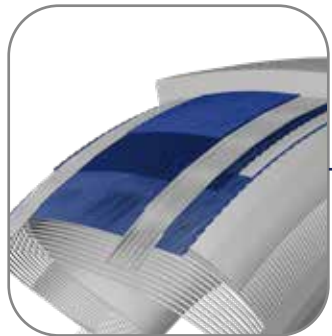

The reinforced Cross Over Bead, combined with the new geometry of the rectangular wire steel, ensures:

- great **flexibility**
- bead seating with superior **longevity** throughout the entire casing life cycle
- excellent resistance to **high load capacities**

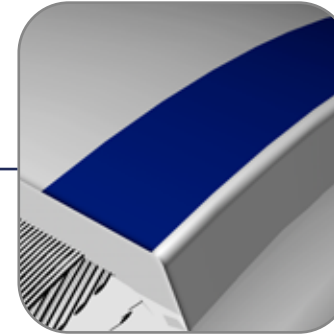

The innovative Step Shoulder Rib Profile allows the correct distribution of footprint contact pressure, promoting **even wear** and **mileage**.

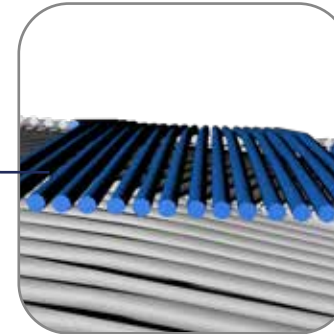

The Spiral Wire Technology materializes in the bigger steel cable diameter enhancing optimization of the total cost of ownership, thanks to:

- high **durability**
- **long tyre life**

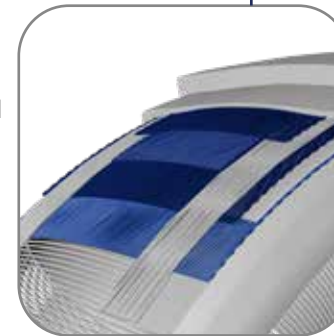

The new High Resistance 4 Belts structure promotes casing flexibility and structural resistance for:

- **extended tyre life**
- **even wear**
- **handling** on uneven road surfaces

The technological package may vary by product line.

# ABBREVIATIONS AND SYMBOLS EXPLANATION

This list contains the explanation of the abbreviations and symbols you can find in the following pages and technical tables.

## EU Tyre Label Regulation 2020/740 - Label parameters:

 = Fuel efficiency class

 = Wet grip class

 = External rolling noise class

 = Snow grip / 3PMSF marking

HL = High Load

M+S = Mud and Snow

FRT = Free Rolling Tyre

POR = Professional Off Road tyres, out of the scope of EU Regulation 2020/740

ML = Mine Logging

MPT = Multi Purpose Tyre

 = Recommended

 = Allowed

 = Also for use on front axles (all wheel drive vehicles)

# PRODUCT RANGE OVERVIEW

## FUEL EFFICIENCY



H02 PROFUEL STEER



PROMETEON



H02 PROFUEL DRIVE



PROMETEON



H02 PRO TRAILER



PROMETEON



315/70 R 22.5	•	•	•	•		
315/80 R 22.5	•	•	•	•		
385/55 R 22.5	•	•			•	•
385/65 R 22.5	•	•			•	•
435/50 R 19.5					•	
445/45 R 19.5					•	

# PRODUCT RANGE OVERVIEW

VERSATILITY  



	PROMETEON	PIRELLI <small>TRUCK R&amp;T ROAD ONE</small>	PROMETEON	PIRELLI <small>TRUCK R&amp;T ROAD ONE</small>
305/70 R 22.5	•	•		
315/70 R 22.5	•	•	•	•
315/80 R 22.5	•	•	•	•
385/55 R 22.5	•	•		
385/65 R 22.5	•	•		
355/50 R 22.5	•	•		
375/50 R 22.5	•	•		

# PRODUCT RANGE OVERVIEW

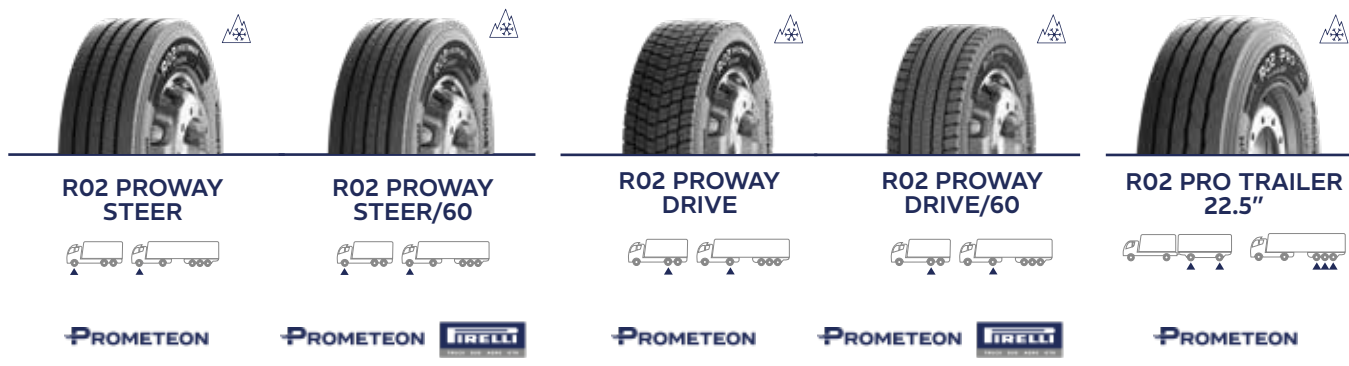

R02 PROWAY STEER

R02 PROWAY STEER/60

R02 PROWAY DRIVE

R02 PROWAY DRIVE/60

R02 PRO TRAILER 22.5"



PROMETEON

PROMETEON

PROMETEON

PROMETEON

PROMETEON

295/60 R 22.5					•	•	
295/80 R 22.5	•			•			
315/60 R 22.5		•	•		•	•	
315/70 R 22.5	•			•			
315/80 R 22.5	•			•			
385/55 R 22.5							•
385/65 R 22.5							•

# PRODUCT RANGE OVERVIEW

VERSATILITY  



205/65 R 17.5						
205/75 R 17.5	•	•	•	•	•	•
215/75 R 17.5	•	•	•	•	•	•
225/75 R 17.5	•	•	•	•	•	•
235/75 R 17.5	•	•	•	•	•	•
245/70 R 17.5	•	•	•	•	•	•
265/70 R 17.5	•	•	•	•	•	•
245/70 R 19.5	•	•	•	•	•	•
265/70 R 19.5	•	•	•	•	•	•
285/70 R 19.5	•	•	•	•	•	•
305/70 R 19.5	•	•	•	•	•	•

# PRODUCT RANGE OVERVIEW

VERSATILITY  



295/80 R 22.5	•	•	
315/70 R 22.5	•	•	
315/80 R 22.5	•	•	
385/55 R 22.5			•
385/65 R 22.5			•

WINTER  

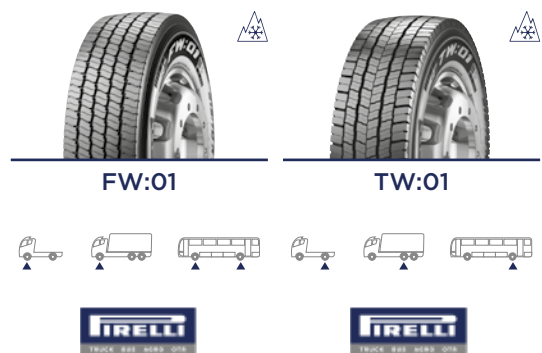
295/80 R 22.5	•	•
315/70 R 22.5	•	•
315/80 R 22.5	•	•
385/55 R 22.5	•	
385/65 R 22.5	•	

# PRODUCT RANGE OVERVIEW

## COACH



C02 COACH  
MULTIAXLE



PROMETEON



C02 COACH  
DRIVE



PROMETEON

295/80 R 22.5  
315/80 R 22.5



## URBAN



U02 URBAN-e  
MULTIAXLE



PROMETEON



MC88 III M+S  
AMARANTO



PIRELLI  
TRUCK 800 4000 010

PIRELLI  
TRUCK 800 4000 010

275/70 R 22.5  
315/60 R 22.5



# PRODUCT RANGE OVERVIEW

## CONSTRUCTION



G02 ECO MULTIAXLE

G02 ECO DRIVE



PROMETEON



PROMETEON



13 R 22.5	•	•	•	•
295/80 R 22.5	•	•	•	•
315/80 R 22.5	•	•	•	•



G02 PRO MULTIAXLE

FG:01 II

TG:01 II

FG88

TG88

MG:01



PROMETEON



13 R 22.5			•	•	•	•	
265/70 R 19.5							•
315/80 R 22.5			•	•	•	•	
385/65 R 22.5	•	•					
425/65 R 22.5	•	•					
295/80 R 22.5			•	•			

# PRODUCT RANGE OVERVIEW

## QUARRY & MINE



TQ:01 ROCK



13 R 22.5



## SPECIAL USE



S02 PISTA



PS22 PISTA



14.00 R 20	•	•
335/80 R 20	•	•
365/80 R 20	•	•
365/85 R 20	•	•
395/85 R 20	•	•



# TECHNICAL TABLES LEGEND

## (S) SECTION WIDTH (MM)

The linear distance between the outsides of the sidewalls of an inflated tyre excluding elevations due to labelling (marking), design application indicators, protective bands or ribs.

## (H) SECTION HEIGHT (MM)

Half difference between the overall diameter and the nominal rim diameter.

## (OD) OVERALL DIAMETER (MM)

The diameter of an inflated tyre at the outermost surface of the tread.

## (RSTAT) STATIC LADEN RADIUS (MM)

The distance between wheel centre and road surface referring to a tyre inflated and loaded at the values shown in the table under static conditions.

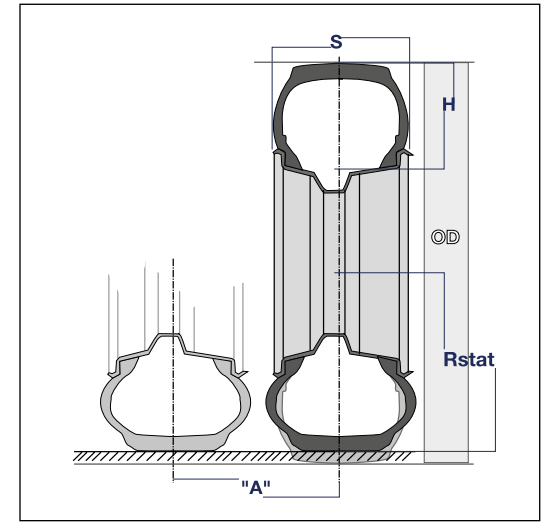

## ROLLING CIRCUMFERENCE (MM)

The distance covered in one complete revolution of the tyre under load and pressure conditions indicated in the tables.

## (A) MINIMUM DUAL SPACING FOR TWIN FITMENTS (MM)

Dual spacing is the distance between the centre lines of the twin tyres. The “A min” values refer to tyres without chains and may also be applied in the case of the fitment of chains for twin tyres. If chains are fitted on one tyre only, the “A min” values must be increased so that the sidewalls of the tyre under load do not trap the chain and become damaged.

## CONVERSION FACTORS

TO CONVERT FROM	INTO	MULTIPLY BY
mm	inch	0.03937
inch	mm	25.4
kg	lbs.	2.2046
lbs.	kg	0.4536
bar	kg/cm <sup>2</sup>	1.01972
kg/cm <sup>2</sup>	bar	0.98066
bar	lbs./sq. inch (psi)	14.5033
lbs./sq. inch (psi)	bar	0.06895
bar	kPa	100
lbs./sq. inch (psi)	kPa	6.895
km/h	m.p.h.	0.62137
m.p.h.	km/h	1.60935

# EU TYRE LABELLING REGULATION

## N. 2020/740

Regulation (EC) No 1222/2009 first introduced the obligation of placing car and van tyres on the EU market with a sticker showing the label with information on the fuel efficiency (rolling resistance), wet grip and external noise of the tyres.

**Under the new (EU) 2020/740 regulation, bus and truck tyres are also covered.**

In addition to fuel efficiency, safety and noise emission, the new EU Energy Label reports also 3PMSF marking and QR code to access to a public database where the label information are stored and accessible to all.

**Careful driving with awareness helps the environment and safety.** Actual fuel savings and road safety heavily depend on drivers' behaviour and correct tyre management and care:

- eco-driving can significantly reduce fuel consumption;
- tyre pressure needs to be regularly checked to optimize fuel efficiency and wet grip;
- braking distances must always be respected.

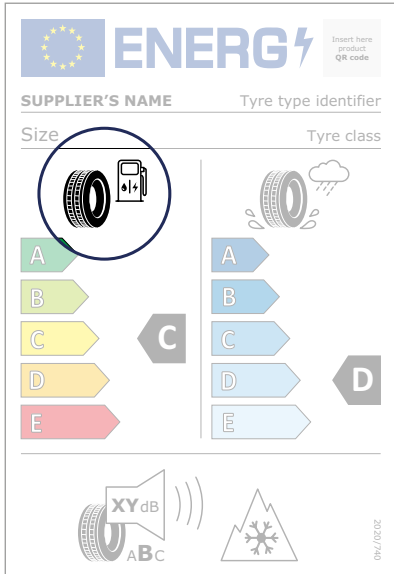

### FUEL EFFICIENCY associated to the tyre's rolling resistance.

Rolling Resistance is a force acting opposite to the travel direction when the tyre is rolling.

Considering that tyres contribute up to 20% of the overall fuel consumption for a car and up to 33% for a truck (for long haulage application), it is important to reach low Rolling Resistance values.

Let's understand how it works: due to the vehicle load, the tyre is deformed in the contact area with the road surface dissipating energy in form of heat. The higher deformations, the higher the rolling resistance and consequently more fuel consumption and CO2 emissions.

In the EU tyre regulation label, rolling resistance is expressed in grades, ranging from A (best grading) to E (worst grading) for industrial vehicles and cars.

# EU TYRE LABELLING REGULATION

N. 2020/740

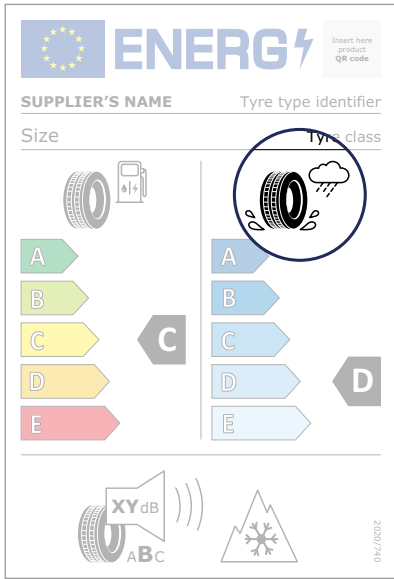

## SAFETY associated to the tyre's wet grip.

Wet grip is one of the most important safety performance of a tyre. Excellent grip on wet means shorter braking distances when driving in rainy weather.

There are other important parameters which are relevant for safety, but wet grip was chosen as the most representative situation in order to compare different tyres.

It ranges from A (shorter braking distance on wet asphalt) to E for truck. The difference between each grade means an increase or decrease in stopping distance of roughly 2 and 3 meters when braking from 60 km/h to 20Kmh.

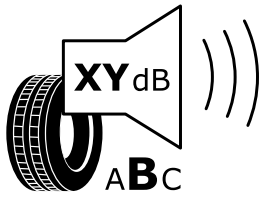
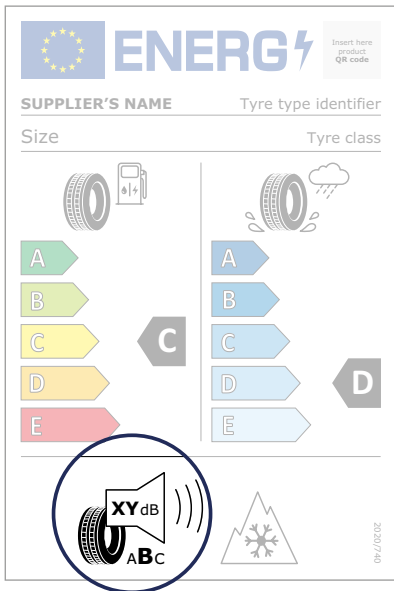

## EXTERNAL NOISE LEVEL (given in decibels)

Traffic noise is a relevant environmental issue determined by several factors such as traffic intensity, vehicle type, driving style, tyre-road interaction.

The value indicated in the label is not the internal that the driver will perceive while driving, but the external one, that is contributing to acoustic pollution.

It is expressed in decibel (dB) and split in 3 categories:

- A class (best performance): at least 3dB less than the Limit Value of EU reg. 661/2009;
- B class: compliant with the limit value of EU reg 661/2009;
- C class (worst performance): compliant with homologative limits but over the limit value of EU reg. 661/2009.

# EU TYRE LABELLING REGULATION

N. 2020/740

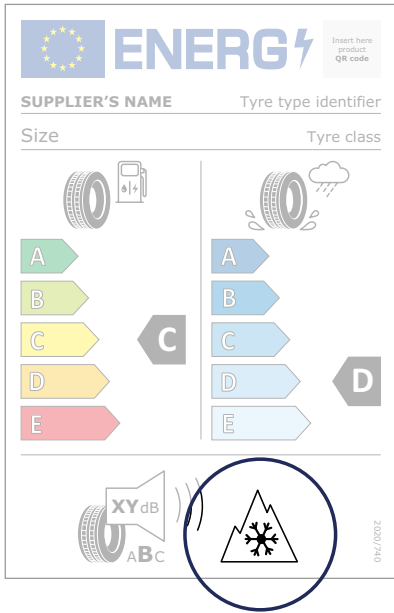

## TYRE FOR USE IN SEVERE SNOW CONDITIONS

(3PMSF symbol)

The tyre bearing this symbol is specifically designed for use in severe snow conditions and can bear the symbol only after a specific test for the measurement of snow grip performances.

The pictogram known as 'Alpine Symbol' or '3 Peaks Mountain Snow Flake' or (3PMSF) is also included on the tyre label of a tyre which satisfies the minimum snow grip index values set out in the 2020/740 regulation that provide also the testing method.

Many European countries are increasing the adoption of legislations that allow the vehicles circulation during winter season only to vehicles provided with tyres bearing Alpine Symbol in some different conditions (roads, regions or periods).

## EPREL database / Product information sheet (European Product Registry for Energy Labelling)

According to the EU label regulation 2020/740, tires sold in Europe must have an Energy Label and the related information must be registered on the EPREL. Through the QR code displayed on the Label or Trademark and Tyre Type Identifier, consumers can access the public web portal and download:

- official EU Label values;
- product information sheet, which includes the designation data and grading for each Tyre Type Identifier.







# TYRE LABELLING TABLE

## PREMIUM

APPLICATION SEGMENT	BRAND	TREAD PATTERN	RIM	IP CODE	EAN CODE	SIZE	LOAD INDEX & SPEED CODE	ADDITIONAL SPECS	MARKING	EU TYRE LABEL REGULATION 2020/740 LABEL PARAMETERS				
														
<b>FUEL EFFICIENCY</b> 	Pirelli	HO2 Profuel Steer	22.5	6042900	8019227604290	315/70 R 22.5	158/150 L (156/150 M)		M+S	A	B	A	67dB	✓
	Prometeon			6064200	8059033606422	315/70 R 22.5	158/150 L (156/150 M)		M+S	A	B	A	67dB	✓
	Pirelli			6008200	8019227600827	315/80 R 22.5	158/150 L (156/150 M)		M+S	A	B	A	71dB	✓
	Prometeon			6063700	8059033606378	315/80 R 22.5	158/150 L (156/150 M)		M+S	A	B	A	71dB	✓
	Pirelli			4169500	8019227416954	385/55 R 22.5	162 K (158 L)	HL	M+S	A	B	A	71dB	✓
	Prometeon			6052200	8059033605227	385/55 R 22.5	162 K (158 L)	HL	M+S	A	B	A	71dB	✓
	Pirelli			6003900	8019227600391	385/65 R 22.5	164 K (158 L)	HL	M+S	A	B	A	71dB	✓
	Prometeon			6067700	8059033606774	385/65 R 22.5	164 K (158 L)	HL	M+S	A	B	A	71dB	✓
	Pirelli	HO2 Profuel Drive	22.5	6043000	8019227604306	315/70 R 22.5	158/150 L (156/150 M)		M+S	A	B	A	72dB	✓
	Prometeon			6052300	8059033605234	315/70 R 22.5	158/150 L (156/150 M)		M+S	A	B	A	72dB	✓
	Pirelli			6008300	8019227600834	315/80 R 22.5	158/150 L (156/150 M)		M+S	A	B	A	73dB	✓
	Prometeon			6064600	8059033606460	315/80 R 22.5	158/150 L (156/150 M)		M+S	A	B	A	73dB	✓
	Prometeon	HO2 Pro Trailer	22.5	6067300	8059033606736	385/55 R 22.5	164 K	HL/FRT	M+S	A	A	A	69dB	✓
	Pirelli			6007600	8019227600766	385/55 R 22.5	164K	HL/FRT	M+S	A	B	A	69dB	✓
	Prometeon			6067500	8059033606750	385/65 R 22.5	164 K (158 L)	HL/FRT	M+S	A	B	A	71dB	✓
	Pirelli	HO2 Pro Trailer	19.5	6007500	8019227600759	385/65 R 22.5	164 K (158 L)	HL/FRT	M+S	A	B	A	71dB	✓
	Prometeon			6067200	8059033606729	435/50 R 19.5	164 J	HL/FRT	M+S	A	B	A	69dB	✓
	Prometeon			6067100	8059033606712	445/45 R 19.5	164 J	HL/FRT	M+S	B	B	A	69dB	✓

# TYRE LABELLING TABLE

## PREMIUM

APPLICATION SEGMENT	BRAND	TREAD PATTERN	RIM	IP CODE	EAN CODE	SIZE	LOAD INDEX & SPEED CODE	ADDITIONAL SPECS	MARKING	EU TYRE LABEL REGULATION 2020/740 LABEL PARAMETERS					
															
<b>VERSATILITY</b> 	Pirelli	R02 Profuel Steer	22.5	6043100	8019227604313	315/70 R 22.5	158/150 L (156/150 M)		M + S	B	B	A	69dB	V	
	Pirelli			6023800	8019227602388	305/70 R 22.5	154/150 L		M+S	B	B	A	69dB	V	
	Prometeon			6051100	8059033605111	305/70 R 22.5	154/150 L		M+S	B	B	A	69dB	V	
	Prometeon			6052900	8059033605296	315/70 R 22.5	158/150 L (156/150 M)		M+S	B	B	A	69dB	V	
	Pirelli			4090200	8019227409024	315/80 R 22.5	158/150 L (156/150 M)		M+S	B	C	A	69dB	V	
	Prometeon			6064700	8059033606477	315/80 R 22.5	158/150 L (156/150 M)		M+S	B	C	A	69dB	V	
	Pirelli			4124700	8019227412475	355/50 R 22.5	156 L		M+S	B	C	A	69dB	V	
	Prometeon			6063200	8059033606323	355/50 R 22.5	156 L		M+S	B	C	A	69dB	V	
	Pirelli			6041800	8019227604184	375/50 R 22.5	158 L		M+S	B	B	A	70dB	V	
	Prometeon			6052100	8059033605210	375/50 R 22.5	158 L		M+S	B	B	A	70dB	V	
	Pirelli			4169600	8019227416961	385/55 R 22.5	162 K (158 L)		M+S	B	B	A	69dB	V	
	Prometeon			6026000	8059033602608	385/55 R 22.5	162 K (158 L)		M+S	B	B	A	69dB	V	
	Pirelli			6007300	8019227600735	385/65 R 22.5	164 K (158 L)		HL	M+S	B	B	A	70dB	V
	Prometeon			6067600	8059033606767	385/65 R 22.5	164 K (158 L)		HL	M+S	B	B	A	70dB	V
	Pirelli			4133500	8019227413359	245/70 R 19.5	136/134 M		M+S	C	B	A	70dB	V	
	Prometeon			6066100	8059033606613	245/70 R 19.5	136/134 M		M+S	C	B	A	70dB	V	
	Pirelli			4133700	8019227413373	265/70 R 19.5	140/138 M		M+S	C	B	A	70dB	V	
	Prometeon			6066200	8059033606620	265/70 R 19.5	140/138 M		M+S	C	B	A	70dB	V	
	Pirelli			4090500	8019227409055	285/70 R 19.5	146/144 L		M+S	B	B	A	72dB	V	
	Prometeon			6065800	8059033606583	285/70 R 19.5	146/144 L		M+S	B	B	A	72dB	V	
	Pirelli			4154400	8019227415445	305/70 R 19.5	148/145 M		M+S	C	C	A	72dB	V	
	Prometeon	6065900	8059033606590	305/70 R 19.5	148/145 M		M+S	C	C	A	72dB	V			
	Pirelli	4133900	8019227413397	205/75 R 17.5	124/122 M		M+S	C	B	A	68dB	V			
	Prometeon	6068100	8059033606811	205/75 R 17.5	124/122 M		M+S	C	B	A	68dB	V			
	Pirelli	4132900	8019227413298	215/75 R 17.5	128/126 M		M+S	C	B	A	69dB	V			
	Prometeon	6051900	8059033605197	215/75 R 17.5	128/126 M		M+S	C	B	A	69dB	V			
	Pirelli	4090700	8019227409079	225/75 R 17.5	129/127 M		M+S	C	B	A	69dB	V			
	Prometeon	6068400	8059033606842	225/75 R 17.5	129/127 M		M+S	C	B	A	69dB	V			
	Pirelli	4133100	8019227413311	235/75 R 17.5	132/130 M		M+S	C	B	A	70dB	V			
	Prometeon	6068500	8059033606859	235/75 R 17.5	132/130 M		M+S	C	B	A	70dB	V			
	Pirelli	4133300	8019227413335	245/70 R 17.5	136/134 M		M+S	C	B	A	71dB	V			
	Prometeon	6068700	8059033606873	245/70 R 17.5	136/134 M		M+S	C	B	A	71dB	V			
	Pirelli	4103400	8019227410341	265/70 R 17.5	140/138 M		M+S	C	B	A	71dB	V			
Prometeon	6068900	8059033606897	265/70 R 17.5	140/138 M		M+S	C	B	A	71dB	V				

# TYRE LABELLING TABLE

## PREMIUM

APPLICATION SEGMENT	BRAND	TREAD PATTERN	RIM	IP CODE	EAN CODE	SIZE	LOAD INDEX & SPEED CODE	ADDITIONAL SPECS	MARKING	EU TYRE LABEL REGULATION 2020/740 LABEL PARAMETERS				
														
<b>VERSATILITY</b> 	Pirelli	R02 Profuel Drive	22.5	6043200	8019227604320	315/70 R 22.5	158/150 L (156/150 M)		M + S	B	B	A	72dB	✓
	Prometeon			6053000	8059033605302	315/70 R 22.5	158/150 L (156/150 M)		M+S	B	B	A	72dB	✓
	Pirelli			4090300	8019227409031	315/80 R 22.5	158/150 L (156/150 M)		M+S	B	B	B	74dB	✓
	Prometeon	6063500	8059033606354	315/80 R 22.5	158/150 L (156/150 M)		M+S	B	B	B	74dB	✓		
	Pirelli	R02 Profuel Drive	19.5	4133600	8019227413366	245/70 R 19.5	136/134 M		M+S	C	B	A	73dB	✓
	Prometeon			6066300	8059033606637	245/70 R 19.5	136/134 M		M+S	C	B	A	73dB	✓
	Pirelli			4133800	8019227413380	265/70 R 19.5	140/138 M		M+S	C	B	A	72dB	✓
	Prometeon			6066400	8059033606644	265/70 R 19.5	140/138 M		M+S	C	B	A	72dB	✓
	Pirelli			4090600	8019227409062	285/70 R 19.5	146/144 L		M+S	C	C	A	72dB	✓
	Prometeon			6066500	8059033606651	285/70 R 19.5	146/144 L		M+S	C	C	A	72dB	✓
	Pirelli	R02 Profuel Drive	17.5	4154500	8019227415452	305/70 R 19.5	148/145 M		M+S	C	C	B	74dB	✓
	Prometeon			6066600	8059033606668	305/70 R 19.5	148/145 M		M+S	C	C	B	74dB	✓
	Pirelli			4134000	8019227413403	205/75 R 17.5	124/122 M		M+S	C	C	A	70dB	✓
	Prometeon			6068200	8059033606828	205/75 R 17.5	124/122 M		M+S	C	C	A	70dB	✓
	Pirelli			4133000	8019227413304	215/75 R 17.5	126/124 M		M+S	C	C	A	70dB	✓
	Prometeon			6052000	8059033605203	215/75 R 17.5	126/124 M		M+S	C	C	A	70dB	✓
	Pirelli	R02 Profuel Drive	17.5	4090800	8019227409086	225/75 R 17.5	129/127 M		M+S	C	C	A	71dB	✓
	Prometeon			6068300	8059033606835	225/75 R 17.5	129/127 M		M+S	C	C	A	71dB	✓
	Pirelli			4133200	8019227413328	235/75 R 17.5	132/130 M		M+S	C	C	A	72dB	✓
	Prometeon			6068600	8059033606866	235/75 R 17.5	132/130 M		M+S	C	C	A	72dB	✓
	Pirelli			4133400	8019227413342	245/70 R 17.5	136/134 M		M+S	C	C	A	73dB	✓
	Prometeon			6068800	8059033606880	245/70 R 17.5	136/134 M		M+S	C	C	A	73dB	✓
	Pirelli	R02 Proway Steer	22.5	4103500	8019227410358	265/70 R 17.5	140/138 M		M+S	C	C	A	71dB	✓
	Prometeon			6069000	8059033606903	265/70 R 17.5	140/138 M		M+S	C	C	A	71dB	✓
	Pirelli			6026300	8019227602630	315/60 R 22.5	154/148 L		M+S	B	B	A	70dB	✓
	Prometeon			6048000	8059033604800	315/60 R 22.5	154/148 L		M+S	B	B	A	70dB	✓
	Prometeon			6045300	8059033604534	315/70 5 22.5	158/150 L (156/150 M)		M+S	C	A	B	73dB	✓
	Prometeon			6045500	8059033604558	315/80 R 22.5	158/150 L (156/150 M)		M+S	C	A	B	72dB	✓
	Prometeon	6024900	8059033602493	295/80 R 22.5	154/149 M		M+S	C	B	A	71dB	✓		
	Prometeon	6047900	8059033604794	295/60 R 22.5	150/147 L		M+S	C	B	A	73dB	✓		
Pirelli	6026400	8019227602647	315/60 R 22.5	152/148 L		M+S	C	B	A	72dB	✓			
Prometeon	6063300	8059033606330	315/60 R 22.5	152/148 L		M+S	C	B	A	72dB	✓			
Prometeon	6045400	8059033604541	315/70 R 22.5	158/150 L (156/150 M)		M+S	D	A	B	76dB	✓			
Prometeon	6045600	8059033604565	315/80 R 22.5	158/150 L (156/150 M)		M+S	D	A	B	76dB	✓			
Prometeon	6025000	8059033602509	295/80 R 22.5	152/148 M		M+S	D	B	B	76dB	✓			
Pirelli	6026200	8019227602623	295/60 R 22.5	150/147 L		M+S	C	B	A	73dB	✓			

# TYRE LABELLING TABLE

## PREMIUM

APPLICATION SEGMENT	BRAND	TREAD PATTERN	RIM	IP CODE	EAN CODE	SIZE	LOAD INDEX & SPEED CODE	ADDITIONAL SPECS	MARKING	EU TYRE LABEL REGULATION 2020/740 LABEL PARAMETERS				
														
	Prometeon	R02 Pro Trailer	22.5	6026100	8059033602615	385/55 R 22.5	164 K	HL / FRT	M+S	B	A	A	70dB	V
	Prometeon			6015300	8059033601533	385/65 R 22.5	164K (158L)	HL / FRT	M+S	B	B	A	70dB	V
	Prometeon		6067000	8059033606705	245/70 R 19.5	142/140 K	FRT	M+S	C	B	A	70dB	V	
	Pirelli		6020500	8019227602050	245/70 R 19.5	142/140 K	FRT	M+S	C	B	A	70dB	V	
	Prometeon		6066800	8059033606682	265/70 R 19.5	143/141 K	FRT	M+S	C	A	A	70dB	V	
	Pirelli		6020600	8019227602067	265/70 R 19.5	143/141 K	FRT	M+S	C	A	A	70dB	V	
	Prometeon		6066900	8059033606699	285/70 R 19.5	150/148 K	FRT	M+S	C	C	A	69dB	V	
	Pirelli		6020700	8019227602074	285/70 R 19.5	150/148 K	FRT	M+S	C	C	A	69dB	V	
	Prometeon		6047700	8059033604770	205/65 R 17.5	132/130 J (133 G)	FRT	M+S	D	B	A	68dB	V	
	Pirelli		6020300	8019227602036	205/65 R 17.5	132/130 J (133 G)	FRT	M+S	D	B	A	68dB	V	
	Prometeon		6047800	8059033604787	215/75 R 17.5	136/134 K	FRT	M+S	D	B	A	69dB	V	
	Pirelli		6020400	8019227602043	215/75 R 17.5	136/134 K	FRT	M+S	D	B	A	69dB	V	
	Pirelli		6018200	8019227601824	245/70 R 17.5	143/141 L (146 K)	FRT	M+S	C	B	A	71dB	V	
	Prometeon		6047600	8059033604763	245/70 R 17.5	143/141 L (146 K)	FRT	M+S	C	B	A	71dB	V	
	Prometeon		6047500	8059033604756	235/75 R 17.5	143/141 K (145 J)	FRT	M+S	C	B	A	71dB	V	
	Pirelli		6018100	8019227601817	235/75 R 17.5	143/141 K (145 J)	FRT	M+S	C	B	A	71dB	V	









# TYRE LABELLING TABLE

## PREMIUM

APPLICATION SEGMENT	BRAND	TREAD PATTERN	RIM	IP CODE	EAN CODE	SIZE	LOAD INDEX & SPEED CODE	ADDITIONAL SPECS	MARKING	EU TYRE LABEL REGULATION 2020/740 LABEL PARAMETERS														
																								
<b>WINTER</b> 	Pirelli	FW:01	22.5	2464200	8019227246421	295/80 R 22.5	154/149 M	EXTRA	M+S	C	A	B	72dB	✓										
				2780400	8019227278040	315/70 R 22.5	156/150 L (154/150 M)	EXTRA	M+S	C	B	B	73dB	✓										
				2659800	8019227265989	315/80 R 22.5	156/150 L (154/150 M)		M+S	C	A	B	72dB	✓										
				2659900	8019227265996	385/55 R 22.5	158 L (160 K)		M+S	C	B	B	73dB	✓										
		TW:01	22.5	2660000	8019227266009	385/65 R 22.5	158 L (160 K)	M+S	C	B	B	73dB	✓											
														2647800	8019227264784	295/80 R 22.5	152/148 M		M+S	D	A	B	75dB	✓
														2151200	8019227215120	315/70 R 22.5	154/150 L (152/148 M)		M+S	D	B	B	75dB	✓
														2151000	8019227215106	315/80 R 22.5	156/150 L (154/150 M)		M+S	D	B	B	75dB	✓
<b>COACH</b> 	Prometeon	C02 Coach Multiaxle	22.5	6070200	8059033607023	295/80 R 22.5	156/150 M	HL	M+S	B	B	A	68dB	✓										
		C02 Coach Drive	22.5	6071300	8059033607139	315/80 R 22.5	158/150 L (156/150 M)	HL	M+S	B	A	A	69dB	✓										
				6033300	8059033603339	295/80 R 22.5	156/150 M	HL	M+S	B	B	A	69dB	✓										
<b>URBAN</b> 	Pirelli	U02 Urban-e Pro Multiaxle	22.5	4099600	8019227409963	315/60 R 22.5	156/150 J	HL	M+S	B	B	A	72dB	✓										
	Prometeon	U02 Urban-e Multiaxle	22.5	6064500	8059033606453	315/60 R 22.5	156/150 J	HL	M+S	B	B	A	72dB	✓										
	Pirelli	U02 Urban-e Pro Multiaxle	22.5	4099500	8019227409956	275/70 R22.5	152/148 J	HL	M+S	B	B	A	69dB	✓										
	Prometeon	U02 Urban-e Multiaxle	22.5	6046600	8059033604664	275/70 R22.5	152/148 J	HL	M+S	B	B	A	69dB	✓										

# TYRE LABELLING TABLE

## PREMIUM

APPLICATION SEGMENT	BRAND	TREAD PATTERN	RIM	IP CODE	EAN CODE	SIZE	LOAD INDEX & SPEED CODE	ADDITIONAL SPECS	MARKING	EU TYRE LABEL REGULATION 2020/740 LABEL PARAMETERS				
														
<b>CONSTRUCTION</b> 	Pirelli	G02 Pro Multiaxle	22.5	3936800	8019227393682	385/65 R 22.5	164 K (158 L)	HL	M+S	C	B	B	73dB	✓
	Prometeon			6033500	8059033603353	385/65 R 22.5	164 K (158 L)	HL	M+S	C	B	B	72dB	✓
	Pirelli			6044800	8019227604481	425/65 R 22.5	165 K		M+S	C	B	B	73dB	✓
	Prometeon			6061600	8059033606163	425/65 R 22.5	165 K		M+S	C	B	B	73dB	✓
	Pirelli	G02 Eco Multiaxle	22.5	6005500	8019227600551	13 R 22.5	158/156 K		M+S	C	B	B	72dB	✓
	Prometeon			6050200	8059033605029	13 R 22.5	158/156 K		M+S	C	B	B	72dB	✓
	Pirelli			6008600	8019227600865	295/80 R 22.5	154/149 L		M+S	C	B	A	71dB	✓
	Prometeon			6064800	8059033606484	295/80 R 22.5	154/149 L		M+S	C	B	A	71dB	✓
	Pirelli			6005700	8019227600575	315/80 R 22.5	158/156 K		M+S	C	A	B	72dB	✓
	Prometeon			6063600	8059033606361	315/80 R 22.5	158/156 K		M+S	C	A	B	72dB	✓
	Pirelli	G02 Eco Drive	22.5	6005600	8019227600568	13 R 22.5	158/156 K		M+S	C	B	B	75dB	✓
	Prometeon			6050300	8059033605036	13 R 22.5	158/156K		M+S	C	B	B	75dB	✓
	Pirelli			6008700	8019227600872	295/80 R 22.5	152/149 L		M+S	D	B	B	74dB	✓
	Prometeon			6064300	8059033606439	295/80 R 22.5	152/149L		M+S	D	B	B	74dB	✓
	Pirelli			6005800	8019227600582	315/80 R 22.5	158/156 K		M+S	C	B	B	75dB	✓
	Prometeon			6053600	8059033605364	315/80 R 22.5	158/156 K		M+S	C	B	B	75dB	✓
<b>QUARRY &amp; MINE</b> 	Pirelli	TQ:01 Rock	22.5	4100300	8019227410037	13 R 22.5	158/156 G	HL / POR	M+S					
<b>SPECIAL USE</b> 	Pirelli	PS22 Pista	20	3763500	8019227376357	14.00 R 20	164/160 G	POR/ML	M+S					
	Prometeon	S02 Pista		6022600	8059033602264	14.00 R 20	164/160 K (166 J)	POR	M+S					
	Pirelli	S02 Pista		4156500	8019227415650	14.00 R 20	164/160 K (166 J)	POR/ML	M+S					
	Prometeon	S02 Pista		6051700	8059033605173	14.00 R 20	168/166 K	POR/ML/HD	M+S					
	Pirelli	PS22 Pista		3763600	8019227376364	335/80 R 20	149 K	POR/MPT	M+S					
	Prometeon	S02 Pista		6048300	8059033604831	335/80 R 20	150 K	POR/MPT	M+S					
	Pirelli	PS22 Pista		3763800	8019227376388	365/80 R 20	152 K	POR/MPT	M+S					
	Pirelli	PS22 Pista		3764100	8019227376418	365/85 R 20	164 G	POR	M+S					
	Prometeon	S02 Pista		6048500	8059033604855	365/85 R 20	164 K	POR	M+S					
	Pirelli	PS22 Pista		3764000	8019227376401	395/85 R 20	168 G (161 J)	POR	M+S					
	Prometeon	S02 Pista		6048600	8059033604862	395/85 R 20	168 K	POR	M+S					

POR= Professional Off Road tyres, out of the scope of EU Regulation 2020/740







# TYRE LABELLING TABLE

## PERFORMANCE

APPLICATION SEGMENT	BRAND	TREAD PATTERN	RIM	IP CODE	EAN CODE	SIZE	LOAD INDEX & SPEED CODE	ADDITIONAL SPECS	MARKING	EU TYRE LABEL REGULATION 2020/740 LABEL PARAMETERS				
														
<b>VERSATILITY</b> 	Pirelli	Itineris S	22.5	3750400	8019227375046	295/80 R 22.5	154/149 M		M+S	C	B	A	69dB	✓
				3220200	8019227322026	315/70 R 22.5	156/150 L (154/150 M)		M+S	C	B	A	72dB	✓
				3103700	8019227310375	315/80 R 22.5	156/150 L (154/150 M)		M+S	D	B	A	72dB	✓
		Itineris D	22.5	6004000	8019227600407	295/80 R 22.5	152/148 M		M+S	D	C	A	73dB	✓
				6004100	8019227600414	315/70 R 22.5	154/150 L (152/148 M)		M+S	D	C	B	74dB	✓
				6004200	8019227600421	315/80 R 22.5	156/150 L (154/150 M)		M+S	D	C	A	73dB	✓
		Itineris T	22.5	2866100	8019227286618	385/55 R 22.5	160 K		M+S	B	A	B	71dB	✓
				6078200	8019227607826	385/65 R 22.5	160 K (158 L)	FRT	M+S	C	A	A	70dB	✓
		<b>URBAN</b> 	Pirelli	MC88 III	22.5	4169900	8019227416992	275/70 R 22.5	150/148 J (152/148 E)	AM	M+S	C	B	B
<b>CONSTRUCTION</b> 	Pirelli	FG:01 II	22.5	3558300	8019227355833	295/80 R 22.5	152/148 L		M+S	D	A	B	73dB	✓
				3864700	8019227386479	13 R 22.5	156/150 K		M+S	D	A	A	71dB	✓
				3535200	8019227353525	315/80 R 22.5	156/150 K		M+S	D	A	A	71dB	✓
		TG:01 II	22.5	3558400	8019227355840	295/80 R 22.5	152/148 L		M+S	E	A	B	76dB	✓
				3864800	8019227386486	13 R 22.5	156/150 K		M+S	D	A	B	74dB	✓
				3558500	8019227355857	315/80 R 22.5	156/150 K		M+S	E	B	B	74dB	✓
		FG88	22.5	2391400	8019227239140	13 R 22.5	156/150 K		M+S	D	B	A	70dB	✓
				1913200	8019227191325	315/80 R 22.5	156/150 K		M+S	D	B	B	72dB	✓
		TG88	22.5	2391500	8019227239157	13 R 22.5	156/150 K		M+S	D	B	B	74dB	✓
				1913300	8019227191332	315/80 R 22.5	156/150 K		M+S	D	B	B	74dB	✓
		MG:01	19.5	6005200	8019227600520	265/70 R 19.5	143/141 K		M+S	D	B	A	72dB	✓

# TYRE LABELLING TABLE

## OTHER PRODUCT LINES

APPLICATION SEGMENT	BRAND	TREAD PATTERN	RIM	IP CODE	EAN CODE	SIZE	LOAD INDEX & SPEED CODE	ADDITIONAL SPECS	MARKING	EU TYRE LABEL REGULATION 2020/740 LABEL PARAMETERS				
														
<b>VERSATILITY</b> 	Pirelli	FR:01 + II	22.5	6000800	8019227600087	295/80 R 22.5	154/149 M		M+S	C	B	A	68dB	✓
				3266800	8019227326680	315/70 R 22.5	156/150 L (154/150 M)	EXTRA	M+S	C	A	B	72dB	✓
				2659700	8019227265972	315/80 R 22.5	156/150 L (154/150 M)		M+S	C	B	A	70dB	✓
		TR:01 + II	22.5	2633000	8019227263305	295/80 R 22.5	152/148 M		M+S	D	B	A	73dB	✓
				3266900	8019227326697	315/70 R 22.5	154/150 L (152/148 M)		M+S	D	B	B	75dB	✓
				2633200	8019227263329	315/80 R 22.5	156/150 L (154/150 M)		M+S	D	B	A	73dB	✓
		FR25	22.5	4112700	8019227411270	11 R 22.5	148/145 L		M+S	D	B	A	68dB	✓
				3609100	8019227360912	12 R 22.5	152/148 M	PLUS	M+S	D	A	A	71dB	✓
				3609000	8019227360905	315/80 R 22.5	156/150 L (154/150 M)	PLUS	M+S	D	A	A	71dB	✓
		TR25	22.5	3802500	8019227380255	295/80 R 22.5	152/148 M	PLUS	M+S	C	A	A	71dB	✓
				1231200	8019227123128	12 R 22.5	152/148 M	PLUS	M+S	E	B	B	75dB	✓
				1184700	8019227118476	315/80 R 22.5	156/150 L (154/150 M)	PLUS	M+S	D	B	B	75dB	✓
		LS97	17.5	4056900	8019227405699	8.5 R 17.5	121/120 M	PLUS	M+S	E	B	A	67dB	✓
			22.5	4116300	8019227411638	10 R 22.5	144/142 M		M+S	D	B	A	71dB	✓
		TH25	20	4116100	8019227411614	11.00 R 20	150/146 L	PLUS	M+S	D	B	A	71dB	✓
22.5	4057100		8019227405712	10 R 22.5	144/142 M		M+S	D	B	B	75dB	✓		
ST25	22.5	2855900	8019227285598	385/65 R 22.5	160 K (158 L)	FRT/ PLUS	M+S	C	A	B	71dB	✓		
<b>CONSTRUCTION</b> 	Pirelli	FG85	24	3780300	8019227378030	12.00 R 24	160/156 K		M+S	D	B	A	71dB	✓
			22.5	3780100	8019227378016	12 R 22.5	152/148 L		M+S	D	A	A	71dB	✓
			20	4141500	8019227414158	10.00 R 20	146/143 K		M+S	D	A	B	72dB	✓
		TG85	20	3780200	8019227378023	12.00 R 20	154/150 K (156/150 G)		M+S	D	B	B	72dB	✓
			24	1204400	8019227120448	12.00 R 24	160/156 K		M+S	D	B	B	74dB	✓
			22.5	1288500	8019227128857	12 R 22.5	152/148 L		M+S	D	B	B	74dB	✓
		20	1204300	8019227120431	12.00 R 20	154/150 K (156/150 G)		M+S	D	B	B	74dB	✓	
			1423900	8019227142396	12.00 R 20	154/150 K (156/150 G)		M+S	E	C	B	74dB	✓	
		APOS	20	4141400	8019227414141	11.00 R 20	150/146K	PLUS	M+S	D	B	B	72dB	✓
				4141600	8019227414165	12.00 R 20	154/150 K (156/150 G)	PLUS	M+S	D	A	B	72dB	✓























# DIMENSIONAL AND LOAD/PRESSURE TABLES

## MULTIPURPOSE & OFF - ROAD 20"

TYRE SIZE	LOAD INDEX & SPEED CODE	BRAND	PR	TREAD PATTERN	MARKING	TYRE DIMENSIONS [MM]							RIMS	MINIMUM DUAL SPACING [MM]	TUBE	FLAP	LOAD INDEX	LOAD CAPACITY PER AXLE (KG)		COLD INFLATION PRESSURE - BAR [KPA] (PSI)												SPEED CODE [KM/H]
						NEW				STANDARD ETRTO								FITMENT		TARMAC MAX. 110 KM/H			GRAVEL MAX. 65 KM/H			OFF-ROAD MAX. 25 KM/H			SAND MAX. 15 KM/H			
						WIDTH (#)	OUTER DIAMETER	STATIC RADIUS	ROLLING CIRC. (±1%)	MAX. WIDTH (#)	MAX. OUTER DIAMETER	ROLLING CIRCUMF. DESIGN						SINGLE	DUAL	[BAR]	[KPA]	[PSI]	[BAR]	[KPA]	[PSI]	[BAR]	[KPA]	[PSI]	[BAR]	[KPA]	[PSI]	
<b>335/80 R 20</b>	149 K	Pirelli	14	PS22 Pista	MPT M+S POR	333	1035	478	3105	354	1066	3132	<u>11</u> 11SDC	-	Tubless (*) (20" Z 596)	(ZD 20)	149	<b>6500</b>	-	6,50	650	94	5,60	560	81	4,45	445	64	4,10	410	59	<b>K = 110</b>
													6300					-	6,25	625	91	5,35	535	78	4,25	425	62	3,90	390	57		
													6100					-	6,00	600	87	5,15	515	75	4,05	405	59	3,75	375	54		
													5890					-	5,75	575	83	4,90	490	71	3,85	385	56	3,55	355	52		
													5690					-	5,50	550	80	4,70	470	68	3,70	370	53	3,40	340	49		
													5480					-	5,25	525	76	4,45	445	65	3,50	350	51	3,20	320	47		
													5270					-	5,00	500	73	4,25	425	62	3,30	330	48	3,05	305	44		
<b>335/80 R 20</b>	150 K	Prometeon	14	S02 Pista	MPT M+S POR	347	1035	492	3204	354	1066	3132	<u>11</u> 11SDC	-	Tubless (*) (20" Z 596)	(ZD 20)	150	<b>6700</b>	-	6,50	650	94	5,60	560	81	4,45	445	64	4,10	410	59	<b>K = 110</b>
													6490					-	6,25	625	91	5,35	535	78	4,25	425	62	3,90	390	57		
													6280					-	6,00	600	87	5,15	515	75	4,05	405	59	3,75	375	54		
													6070					-	5,75	575	83	4,90	490	71	3,85	385	56	3,55	355	52		
													5860					-	5,50	550	80	4,70	470	68	3,70	370	53	3,40	340	49		
													5650					-	5,25	525	76	4,45	445	65	3,50	350	51	3,20	320	47		
													5430					-	5,00	500	73	4,25	425	62	3,30	330	48	3,05	305	44		
<b>365/80 R 20</b>	152 K	Pirelli	14	PS22 Pista	MPT M+S POR	357	1092	502	3276	374	1116	3276	<u>11</u> 11SDC	-	Tubless (*) (20" Z 750)	(ZD 20)	152	<b>7100</b>	-	6,25	625	91	5,35	535	78	4,25	425	62	3,90	390	57	<b>K = 110</b>
													6870					-	6,00	600	87	5,15	515	75	4,05	405	59	3,75	375	54		
													6640					-	5,75	575	83	4,90	490	71	3,85	385	56	3,55	355	52		
													6410					-	5,50	550	80	4,70	470	68	3,70	370	53	3,40	340	49		
													6180					-	5,25	525	76	4,45	445	65	3,50	350	51	3,20	320	47		
													5940					-	5,00	500	73	4,25	425	62	3,30	330	48	3,05	305	44		
													5700					-	4,75	475	69	4,05	405	58	3,15	315	45	2,85	285	42		
<b>365/85 R 20</b>	164 G	Pirelli	18	PS22 Pista	M+S POR	368	1138	522	3471	379	1152	3440	<u>10,0</u> 10,0W	-	Tubless		164	<b>10000</b>	-	8,00	800	116	6,90	690	100	5,55	555	80	5,15	515	75	<b>G = 90</b>
													9750					-	7,75	775	112	6,70	670	97	5,35	535	78	4,95	495	72		
													9500					-	7,50	750	109	6,45	645	94	5,15	515	75	4,80	480	70		
													9240					-	7,25	725	105	6,25	625	91	5,00	500	72	4,60	460	67		

[\*] Also for fitment with tube - [#] on underlined rim of the list - [\$] UN Regulation No. 54

(\*) max 100 km/h



# DIMENSIONAL AND LOAD/PRESSURE TABLES

## MULTIPURPOSE & OFF - ROAD 20"

TYRE SIZE	LOAD INDEX & SPEED CODE	BRAND	PR	TREAD PATTERN	MARKING	TYRE DIMENSIONS [MM]							RIMS	MINIMUM DUAL SPACING [MM]	TUBE	FLAP	LOAD INDEX	LOAD CAPACITY PER AXLE (KG)		COLD INFLATION PRESSURE - BAR [KPA] (PSI)												SPEED CODE [KM/H]	
						NEW				STANDARD ETRTO								FITMENT	TARMAC MAX. 110 KM/H			GRAVEL MAX. 65 KM/H			OFF-ROAD MAX. 25 KM/H			SAND MAX. 15 KM/H					
						WIDTH (#)	OUTER DIAMETER	STATIC RADIUS	ROLLING CIRC. (±1%)	MAX. WIDTH (#)	MAX. OUTER DIAMETER	ROLLING CIRCUMF. DESIGN							[BAR]	[KPA]	[PSI]	[BAR]	[KPA]	[PSI]	[BAR]	[KPA]	[PSI]	[BAR]	[KPA]	[PSI]			
						SINGLE	DUAL	[BAR]	[KPA]	[PSI]	[BAR]	[KPA]							[PSI]	[BAR]	[KPA]	[PSI]	[BAR]	[KPA]	[PSI]	[BAR]	[KPA]	[PSI]					
<b>395/85 R 20</b>	168 K	Prometeon	18	S02 Pista	M+S POR	389	1185	542	3614	401	1206	3599	10,0	Tubless		168	<b>11200</b>	-	8,50	850	123	7,35	735	107	5,90	590	86	5,50	550	80	<b>K = 110</b>		
													10,0W				10940	-	8,25	825	120	7,15	715	103	5,70	570	83	5,30	530	77			
													10670				-	8,00	800	116	6,90	690	100	5,55	555	80	5,15	515	75				
													10400				-	7,75	775	112	6,70	670	97	5,35	535	78	4,95	495	72				
													10130				-	7,50	750	109	6,45	645	94	5,15	515	75	4,80	480	70				
													9860				-	7,25	725	105	6,25	625	91	5,00	500	72	4,60	460	67				
													9590				-	7,00	700	102	6,00	600	87	4,80	480	70	4,45	445	64				
													9310				-	6,75	675	98	5,80	580	84	4,60	460	67	4,25	425	62				
													9040				-	6,50	650	94	5,60	560	81	4,45	445	64	4,10	410	59				
													8760				-	6,25	625	91	5,35	535	78	4,25	425	62	3,90	390	57				
																-	-	-	-	-	-	-	-	-	-								
<b>14.00 R 20</b>	164/160 G	Pirelli	22	PS22 Pista	ML M+S POR	389	1245	567	3797	405 (§)	1341 (§)	3861 (§)	10	Tubless (*)		164	<b>10000</b>	<b>18000</b>	7,50	750	109	6,45	645	94	5,15	515	75	4,80	480	70	<b>G = 90</b>		
													10,0OV				10,00W	428	9730	17520	7,25	725	105	6,25	625	91	5,00	500	72	4,60		460	67
													9,0				9460	17030	7,00	700	102	6,00	600	87	4,80	480	70	4,45	445	64			
																	9190	16540	6,75	675	98	5,80	580	84	4,60	460	67	4,25	425	62			
																	8920	16050	6,50	650	94	5,60	560	81	4,45	445	64	4,10	410	59			
																	8640	15560	6,25	625	91	5,35	535	78	4,25	425	62	3,90	390	57			
																	8370	15060	6,00	600	87	5,15	515	75	4,05	405	59	3,75	375	54			
																	8090	14550	5,75	575	83	4,90	490	71	3,85	385	56	3,55	355	52			
																	7800	14040	5,50	550	80	4,70	470	68	3,70	370	53	3,40	340	49			
<b>14.00 R 20</b>	164/160 K (166 J)	Pirelli	22	S02 Pista	ML M+S POR	389	1245	567	3797							164	<b>10000</b>	<b>18000</b>	7,50	750	109	6,45	645	94	5,15	515	75	4,80	480	70	<b>K = 110</b>		
													160				9730	17520	7,25	725	105	6,25	625	91	5,00	500	72	4,60	460	67			

[\*] Also for fitment with tube - [#] on underlined rim of the list - [§] UN Regulation No. 54

(\*) max 100 km/h

# DIMENSIONAL AND LOAD/PRESSURE TABLES

## MULTIPURPOSE & OFF - ROAD 20"

TYRE SIZE	LOAD INDEX & SPEED CODE	BRAND	PR	TREAD PATTERN	MARKING	TYRE DIMENSIONS [MM]							RIMS	MINIMUM DUAL SPACING [MM]	TUBE	FLAP	LOAD INDEX	LOAD CAPACITY PER AXLE (KG)		COLD INFLATION PRESSURE - BAR [KPA] (PSI)												SPEED CODE [KM/H]
						NEW				STANDARD ETRTO								FITMENT		TARMAC MAX. 110 KM/H			GRAVEL MAX. 65 KM/H			OFF-ROAD MAX. 25 KM/H			SAND MAX. 15 KM/H			
						WIDTH (#)	OUTER DIAMETER	STATIC RADIUS	ROLLING CIRC. (±1%)	MAX. WIDTH (#)	MAX. OUTER DIAMETER	ROLLING CIRCUMF. DESIGN						SINGLE	DUAL	[BAR]	[KPA]	[PSI]	[BAR]	[KPA]	[PSI]	[BAR]	[KPA]	[PSI]	[BAR]	[KPA]	[PSI]	
<b>14.00 R 20</b>	164/160 K (166 J)	Prometeon	22	S02 Pista	ML M+S POR	389	1245	567	3797							(166)	9460	17030	7.00	700	102	6,00	600	87	4,80	480	70	4,45	445	64	<b>J = 100</b>	
																	9190	16540	6.75	675	98	5,80	580	84	4,60	460	67	4,25	425	62		
																	8920	16050	6.50	650	94	5,60	560	81	4,45	445	64	4,10	410	59		
																	8640	15560	6.25	625	91	5,35	535	78	4,25	425	62	3,90	390	57		
																	8370	15060	6.00	600	87	5,15	515	75	4,05	405	59	3,75	375	54		
																	8090	14550	5.75	575	83	4,90	490	71	3,85	385	56	3,55	355	52		
																	7800	14040	5.50	550	80	4,70	470	68	3,70	370	53	3,40	340	49		
																	<b>(10600)</b>	<b>(18000)</b>	<b>7,50 (*)</b>	<b>750</b>	<b>109</b>	<b>-</b>	<b>-</b>	<b>-</b>	<b>-</b>	<b>-</b>	<b>-</b>	<b>-</b>	<b>-</b>	<b>-</b>		<b>-</b>
<b>14.00 R 20</b>	168/166 K	Prometeon	22	S02 Pista	ML M+S POR	376	1240	567	3782	377	1268	3776	10	426	Tubless (*)	168	<b>11200</b>	<b>21200</b>	8,50	850	123	7,35	735	107	5,90	590	86	5,50	550	80	<b>K = 110</b>	
													10,00W	426	(20" Z 810)		10940	20680	8,25	825	120	7,15	715	103	5,70	570	83	5,30	530	77		
													9,0	414	(U 20-9,0)		10660	20200	8,00	800	116	6,90	690	100	5,55	555	80	5,15	515	75		
																	10400	19680	7,75	775	112	6,70	670	97	5,35	535	78	4,95	495	72		
																	10140	19200	7,50	750	109	6,45	645	94	5,15	515	75	4,80	480	70		
																	9860	18680	7,25	725	105	6,25	625	91	5,00	500	72	4,60	460	67		
																	9580	18160	7,00	700	102	6,00	600	87	4,80	480	70	4,45	445	64		
																	9320	17640	6,75	675	98	5,80	580	84	4,60	460	67	4,25	425	62		
																	9040	17120	6,50	650	94	5,60	560	81	4,45	445	64	4,10	410	59		

# LOAD LIMITS AT VARIOUS SPEEDS

## TRUCK TYRES WITH LOAD INDEX $\geq 122$ AS A SINGLE FITMENT

MAXIMUM VEHICLE SPEED [KM/H]	SPEED SYMBOLS						PRESSURE COEFFICIENT
	F=80	G=90	J=100	K=110	L=120	M=130	
	LOAD COEFFICIENTS						
130						<b>1,00</b>	1,00
125						1,00	1,00
120					<b>1,00</b>	1,00	1,00
115					1,00	1,00	1,00
110				<b>1,00</b>	1,00	1,00	1,00
105				1,00	1,00	1,00	1,00
100			<b>1,00</b>	1,00	1,00	1,00	1,00
95			1,01	1,01	1,01	1,01	1,00
90		<b>1,00</b>	1,02	1,02	1,02	1,02	1,00
85		1,02	1,03	1,03	1,03	1,03	1,00
80	<b>1,00</b>	1,04	1,04	1,04	1,04	1,04	1,00
75	1,025	1,055	1,055	1,055	1,055	1,055	1,01
70	1,05	1,07	1,07	1,07	1,07	1,07	1,02
65	1,075	1,085	1,085	1,085	1,085	1,085	1,04
60	1,10	1,10	1,10	1,10	1,10	1,10	1,06
55	1,11	1,11	1,11	1,11	1,11	1,11	1,07
50	1,12	1,12	1,12	1,12	1,12	1,12	1,08
45	1,13	1,13	1,13	1,13	1,13	1,13	1,09
40 (a) (b)	1,15	1,15	1,15	1,15	1,15	1,15	1,10
35	1,19	1,19	1,19	1,19	1,19	1,19	1,11
30	1,25	1,25	1,25	1,25	1,25	1,25	1,13
25	1,35	1,35	1,35	1,35	1,35	1,35	1,17
20	1,50	1,50	1,50	1,50	1,50	1,50	1,21
15	1,65	1,65	1,65	1,65	1,65	1,65	1,25
10	1,80	1,80	1,80	1,80	1,80	1,80	1,30
5	2,10	2,10	2,10	2,10	2,10	2,10	1,40
STATIC	2,50	2,50	2,50	2,50	2,50	2,50	1,40

(a) The load carrying capacity of tyres in dual fitment is twice the load carrying capacity in single up to 40 km/h;  
 (b) Bonus loads will not be permitted for speeds above 40 km/h if the wheel axles are rigidly fixed to the body of the vehicle.

# LOAD AND SPEED TABLES

## CONVERSION OF LOAD INDICES (LI) INTO LOAD CAPACITIES PER TYRE [KG AND LBS]

LI	KG	LBS
80	450	990
81	462	1020
82	475	1045
83	487	1075
84	500	1100
85	515	1135
86	530	1170
87	545	1200
88	560	1235
89	580	1280
90	600	1325
91	615	1355
92	630	1390
93	650	1435
94	670	1475
95	690	1520
96	710	1565
97	730	1610
98	750	1655
99	775	1710
100	800	1765
101	825	1820
102	850	1875
103	875	1930
104	900	1985
105	925	2040
106	950	2095
107	975	2150
108	1000	2205
109	1030	2270
110	1060	2335

LI	KG	LBS
111	1090	2405
112	1120	2470
113	1150	2535
114	1180	2600
115	1215	2680
116	1250	2755
117	1285	2835
118	1320	2910
119	1360	3000
120	1400	3085
121	1450	3195
122	1500	3305
123	1550	3415
124	1600	3525
125	1650	3640
126	1700	3750
127	1750	3860
128	1800	3970
129	1850	4080
130	1900	4190
131	1950	4300
132	2000	4410
133	2060	4540
134	2120	4675
135	2180	4805
136	2240	4940
137	2300	5070
138	2360	5205
139	2430	5355
140	2500	5510

LI	KG	LBS
141	2575	5675
142	2650	5840
143	2725	6010
144	2800	6175
145	2900	6395
146	3000	6615
147	3075	6780
148	3150	6945
149	3250	7165
150	3350	7385
151	3450	7605
152	3550	7825
153	3650	8045
154	3750	8265
155	3875	8545
156	4000	8820
157	4125	9095
158	4250	9370
159	4375	9645
160	4500	9920
161	4625	10195
162	4750	10470
163	4875	10745
164	5000	11025
165	5150	11355
166	5300	11685
167	5450	12015
168	5600	12345
169	5800	12785
170	6000	13230

## SPEED SYMBOLS [KM/H & MPH]

SYMBOL	E	F	G	J	K	L	M	N	P	Q	R	S	T
KM/H	70	80	90	100	110	120	130	140	150	160	170	180	190
M.P.H.	43	50	56	62	68	75	81	87	93	99	106	112	118

# RADIO FREQUENCY IDENTIFICATION DEVICE (RFID)

The **RFID** chip is a smart electronic component that receives and transmits radio signals (without cables). It is incorporated inside the tyre and allows for simple identification and easy connection to tyre management and tracking systems. RFID contains ISO-encoded unique tyre identification according to the SGTIN96 standard.

The RFID is unique for each tyre and its duration is the same as that of the carcass thanks to its resistance to retreadability operations. RFID chip is present on all SERIE02 products\*.

## BENEFITS

### **Time savings** and **productivity:**

- digital and direct traceability of the tyres
- effective management and maintenance of the tyres stock

### **Tyres monitoring** and **relative services:**

- easy recording of mileage performances during multiple tyre lives
- traceability of maintenance and reconstruction operations
- easy and quick tyre recognition

### **Stock optimization:**

- simple and reliable inventory of tyres stock



The RFID on tyres produced by Prometeon is always located on DOT side while, in the opposite DOT side, is marked with:



\* except 315/60 R 22.5 U02 Urban-e Pro Multiaxle

# INFLATION PRESSURE

This is one of the factors that mostly influences tyre efficiency. It is the compressed gas in the tyre that supports the load. Incorrect pressure, whether associated with overinflation or underinflation, will either have the effect of over “supporting” the tyre and causing casing stress, or under “supporting” it, with a consequent increase in flexing and generation of an excessive amount of heat, and this may cause tyre failure. Flexing during service is a function of the load supported by the tyre and of the inflation pressure; it is predetermined in the design phase to optimise the tyre performance. **Inflation pressure must always depend upon the actual load per axle, to guarantee the proper tyre flexing.** Overload leads to similar effects as underinflation. When the correct pressure is used even the tyre footprint area, i.e. the contact surface between the tread and the road, will be optimal and this is a determining factor to guarantee even wear.

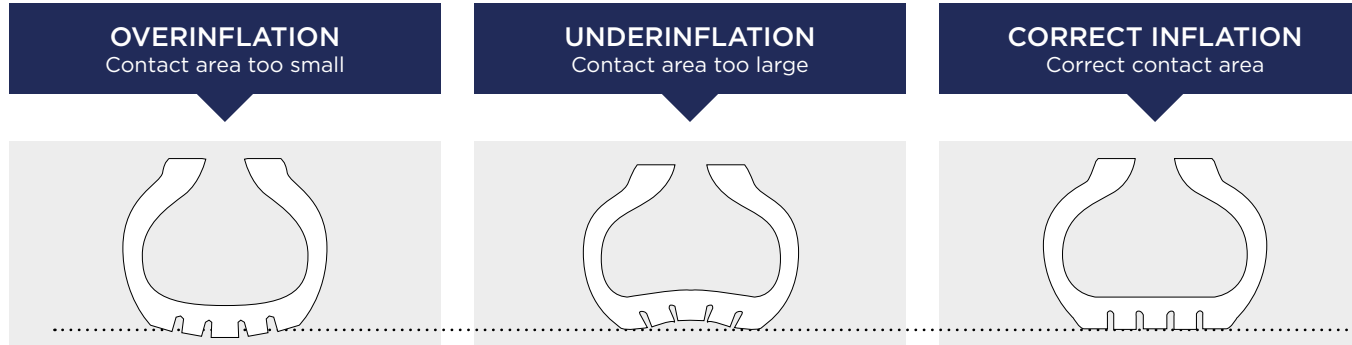

We should recall that the pressure must be measured when the tyre is cold, after the vehicle has been standing for several hours.

With regards to pressure check, we recommend compliance with the following instructions:

USE	PRESSURE CHECK (DAYS)*			
	1	7	10	15
<b>ON/OFF ROAD</b>				
Radius of activity up to 100 km			•	
Radius of activity over 100 km		•		
On building sites in one shift		•		
On building sites in 2/3 shifts	•			
<b>ON</b>				
km covered per month up to 8000 km				•
km covered per month over 8000 km		•		

## DO NOT “BLEED” TYRES

One of the causes of underinflation is the practice of “bleeding” tyres i.e. reducing the pressure in tyres which have run, warmed up and, therefore, increased in pressure above their starting pressure. Due to casing deflection, all tyres generate heat in operation. This causes the inflation air to warm up, it will try to expand but, because it is confined and cannot, the pressure increases. Such increase is quite normal and tyres are designed safely to withstand it. If air is let out to reduce the pressure, it will mean that the tyre is working at too great a deflection for a hot tyre, i.e. it is in fact under inflated in relation to the load carried. The increased deflection will generate even more heat: the tyre may again reach the higher pressure, but it will be hotter still.

(\*) Make sure the valve cap is always properly screwed. The spare wheel must be checked as well.

# STORAGE IN A ROW ON PALLETS (best method)

## STORAGE OF PRODUCTS

Moist conditions should be avoided. Care must be taken to ensure no condensation occurs. Tyres have to be stored inside in cool, dry and moderately ventilated conditions. Skylights and windows have to be positioned such that sunlight does not fall directly onto the stored products. The storage temperature should be ideally between 5°C and 25°C, not above 35°C. The effects of low temperature fall directly onto the stored products. Care should be taken therefore to avoid distorting them during handling at that temperature, because cracks may appear. In case of stacking tyres in piles, the following rules must be followed for method, stack height etc:

	SECTION WIDTH	MAX NO. TYRES PER PILE	NO. OF TYRES FOR ANCHORAGE
Light truck and truck	Up to 8" or 205 mm	10	+2
	9" - 10" or 215-255 mm	9	+2
	11"-12" or 265-315 mm	8	+2
	Over 12" or 315 mm	4	+2

### SHORT TERM STORAGE

Up to 4 weeks, tyres can be stored in stacks, one on top of the other, preferably on a fixed rack or on stackable pallets, reforming the stack inverting the order of the tyres on a weekly basis. In all cases when tyres are stored in stacks, it is necessary to ensure that there is no partial misplacement from the vertical plane, in order to avoid any permanent deformation of the lower tyres in the stack.

The maximum height of the stack must not exceed 1.2m and the tyres in the stack must all be of the same dimension.

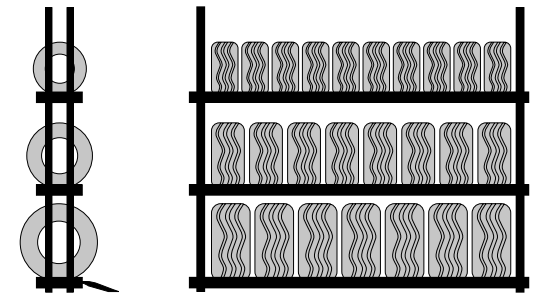

### INNER TUBES AND VALVES

Whether inner tubes are supplied by the producer in single boxes, large boxes or wrapped in plastic film, it is always preferable to maintain the original packaging. In alternative they can be stored also slightly inflated, inserted within the tyre, or piled deflated, up to a maximum height of 50 cm, on racking shelves with a closed base, accurately avoiding that the valve can damage the surface of the tube when squashed under the pressure of their own weight. Ensure that the tubes do not overlap the edge of the plane on which they are stored to avoid accidental laceration. It is not recommended to store on slatted pallets because the pressure applied to the tubes will not be uniform. Do not hang inner tubes during storage. Valves should be stored in their packaging in a clean, well ventilated and dry location.

### FLAPS

Flaps should preferably be placed within the tyre together with the inner tube. If they are stored separately, they should be placed horizontally, in a pile on a shelf, protected from dust, grease, humidity, ozone and direct sunlight. To avoid deformation and stretching they must not be hung up in any way.

### STOCK ROTATION

The storage location must be organized in such a way as to guarantee constant stock rotation, limiting to the minimum the storage period of the tyres. Products which enter storage first must be the first to leave. First in, first out.

A close-up, grayscale image of a tire tread. The tread pattern features several parallel longitudinal grooves. The central portion of the tread is highlighted with a dark blue color, indicating the area of regrooving. The word "PROTEON" is embossed on the sidewall of the tire. The image is overlaid with a semi-transparent white horizontal band containing the text "REGROOVING".

# REGROOVING

# REGROOVING PRINCIPLES

## PREMISE

The regrooving operation consists of cutting into the tread of a tyre a tread pattern deeper than the original so as to prolong its useful life. Mileage is thus increased and costs per kilometre are reduced.

When regrooving it is of fundamental importance to pay attention to avoid exposing the upper belts of the tyre and to ensure that an adequate layer of rubber is left to protect them. In this booklet Prometeon supplies specific instructions regarding the patterns to follow in the regrooving of their tyre treads and the recommended groove widths and depth of rubber to remove from the bottom of the original grooves. The European (EEC) and American (DOT) normatives demand that tyres designed and constructed so as to be suitable for regrooving are marked on both sidewalls with the word REGROOVABLE.

## TECHNICAL REQUIREMENTS

- The regrooving operation must only be carried out by specifically trained personnel. Tyres worn to the point where the original tread pattern is invisible (even in a restricted area) cannot be regrooved as it is impossible to evaluate the depth of the remaining rubber.
- As it is possible that the tyre may be worn unevenly it is important to check that the tread has a residual minimum depth of at least 2-3 mm.
- Before beginning the regrooving operation the tyre must be examined carefully to check that it is in good condition and that it has not already been regrooved. A previous regrooving is immediately recognisable to a specialist operator: the grooves lose their sharp corners, especially in areas with zig-zag grooves and there are characteristic signs (undulations) left by the blade within the grooves. If the tyre has already been regrooved the tread wear indicators (TWI), that is rubber bridges at the base of the tread, will have been removed during the regrooving operation, and the groove bottoms will be smooth.

Regrooving is inappropriate whenever the tread is scraped, cut or torn. Any tyre damage or repairs that have not been well executed must be rectified prior to regrooving.

- Before starting the regrooving operation all foreign bodies (that could damage the cutting tool) must be removed from the tread and the condition of the groove bottoms must be checked.
- The depth of the grooves must be measured at a number of points around the circumference of the tyre. The blade cutting depth must be adjusted in accordance with the minimum measured depth.
- The regrooving must be executed with the specific cutting tool (gouge) equipped with an electrically heated blade, and preferably in a well ventilated place. It is advisable to select a blade profile corresponding to the regrooving width and the profile prescribed for that particular tyre.

In order to adjust the regrooving blade correctly add the minimum remaining tread depth figure (A) to the regrooving thickness (P) specified by the manufacturer for that tyre size and tread pattern.

(figure A)

**EXAMPLE:**

minimum remaining tread depth figure  
prescribed regrooving thickness adjustment  
of gouge depth

A        2,5 mm  
P        3,5 mm  
C = A + P   6,0 mm

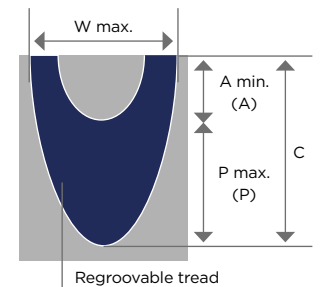

- Fit the tyre onto a proper support. Exert constant pressure and, following the prescribed pattern, cut the rubber at the bottom of the grooves following firstly the circumferential grooves and then the transverse slots where present. After few centimeters measure the regrooving width and depth in order to check the correct choice and size of the blade. For tyres with “Zero Degree Belts” complete the regrooving in the direction of rotation indicated by the equilateral triangle placed on the tyre sidewall.
- By carefully following the procedure described a thickness of rubber is left at the bottom of the groove that is sufficient to protect the upper belts of the tyre. Under no circumstances should the regrooving blade be allowed to shave or notch the metal belts as this would render the tyre unsafe and could compromise subsequent remoulding.

## RESPONSIBILITY

The operator executing the regrooving accepts complete responsibility for the work executed on the tyre and its suitability for use.

## SUPPLEMENTARY ANCHORING

This operation consists of the cutting of supplementary grooves (not deeper than the original ones) or slots in the tyre tread, usually in a diagonal or transverse direction so as to guarantee improved adhesion on slippery surfaces.

The work must be executed by specialists who will assume full responsibility, taking into account the instructions supplied by the tyre manufacturers.

# REGROOVING DATA

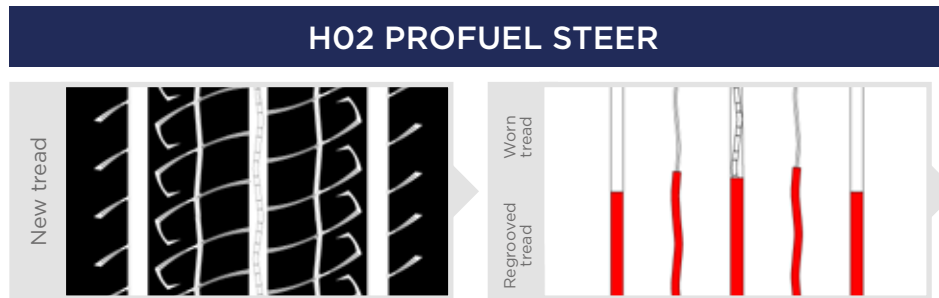

**SIZE RANGE**  
(W. MAX: 8 mm)

SIZE	P MAX (mm)
315/70 R 22.5	2,5
315/80 R 22.5	2,5
385/55 R 22.5	2,5
385/65 R 22.5	2,5

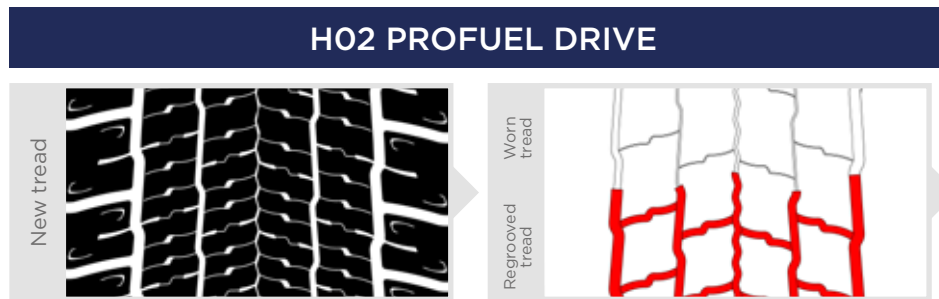

**SIZE RANGE**  
(W. MAX: 8 mm)

SIZE	P MAX (mm)
315/70 R 22.5	2,5
315/80 R 22.5	2,5

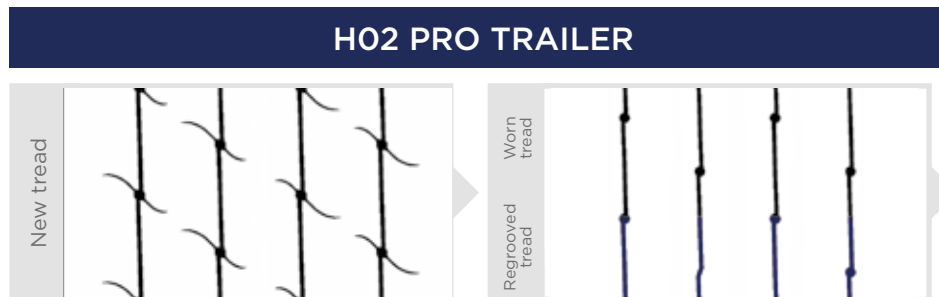

**SIZE RANGE**  
(W. MAX: 8 mm)

SIZE	P MAX (mm)
385/55 R 22.5	2
385/65 R 22.5	2
435/50 R 19.5	2
445/45 R 19.5	2

# REGROOVING DATA

## R02 PROFUEL STEER 22.5

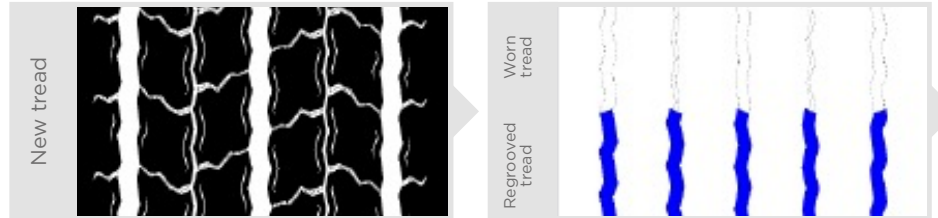

### SIZE RANGE (W. MAX: 8 mm)

SIZE	P MAX (mm)
305/70 R 22.5	2,5
315/70 R 22.5	2,5
315/80 R 22.5	2,5
355/50 R 22.5	2,5
375/50 R 22.5	2,5
385/55 R 22.5	2,5
385/65 R 22.5	2,5

## R02 PROFUEL DRIVE 22.5

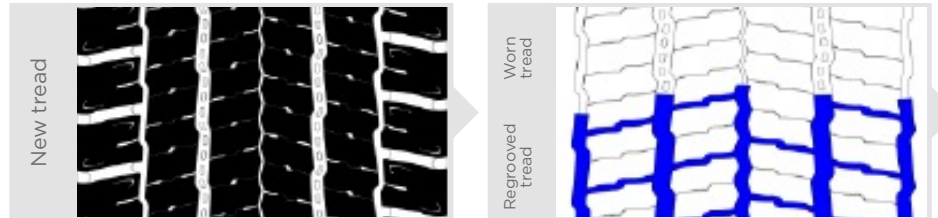

### SIZE RANGE (W. MAX: 8 mm)

SIZE	P MAX (mm)
315/70 R 22.5	2,5
315/80 R 22.5	2,5

## R02 PROFUEL STEER 17.5 - 19.5

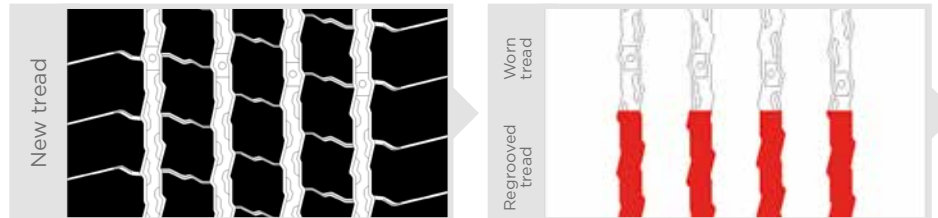

### SIZE RANGE (W. MAX: 8 mm)

SIZE	P MAX (mm)	SIZE	P MAX (mm)
245/70 R 19.5	3,00	205/75 R 17.5	2,0
265/70 R 19.5	3,00	215/75 R 17.5	2,0
285/70 R 19.5	3,00	225/75 R 17.5	2,0
305/70 R 19.5	3,00	235/75 R 17.5	2,0
		245/70 R 17.5	2,0
		265/70 R 17.5	2,0

## R02 PROFUEL DRIVE 17.5 - 19.5

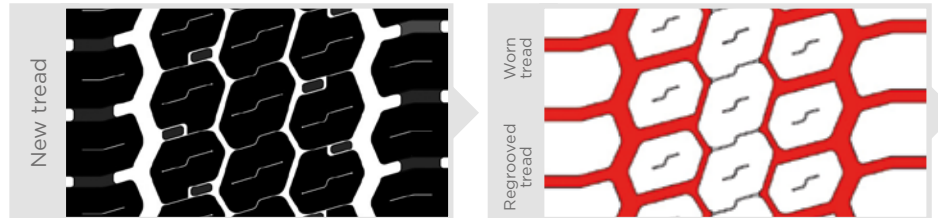

### SIZE RANGE (W. MAX: 8 mm)

SIZE	P MAX (mm)	SIZE	P MAX (mm)
245/70 R 19.5	3,00	205/75 R 17.5	2,0
265/70 R 19.5	3,00	215/75 R 17.5	2,0
285/70 R 19.5	3,00	225/75 R 17.5	2,0
305/70 R 19.5	3,00	235/75 R 17.5	2,0
		245/70 R 17.5	2,0
		265/70 R 17.5	2,0

# REGROOVING DATA



**SIZE RANGE**  
(W. MAX: 8 mm)

SIZE	P MAX (mm)
295/80 R 22.5	2,5
315/70 R 22.5	2,5
315/80 R 22.5	2,5

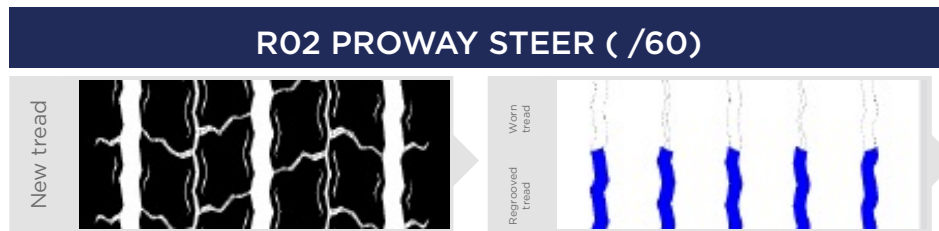

**SIZE RANGE**  
(W. MAX: 8 mm)

SIZE	P MAX (mm)
315/60 R 22.5	3

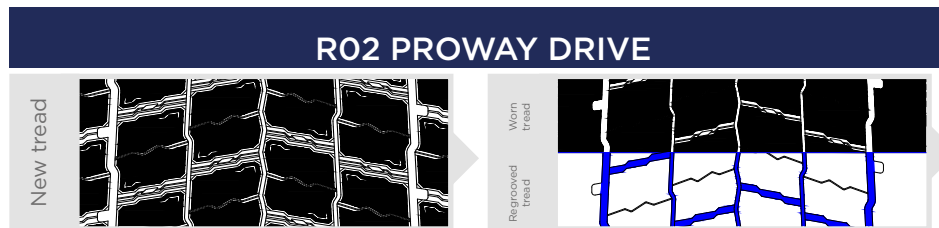

**SIZE RANGE**  
(W. MAX: 8 mm)

SIZE	P MAX (mm)
295/80 R 22.5	2,5
315/70 R 22.5	2,5
315/80 R 22.5	2,5

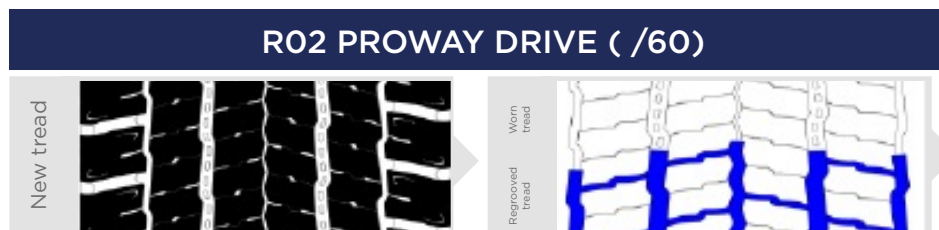

**SIZE RANGE**  
(W. MAX: 8 mm)

SIZE	P MAX (mm)
295/60 R 22.5	3
315/60 R 22.5	3

# REGROOVING DATA

## R02 PRO TRAILER 22.5

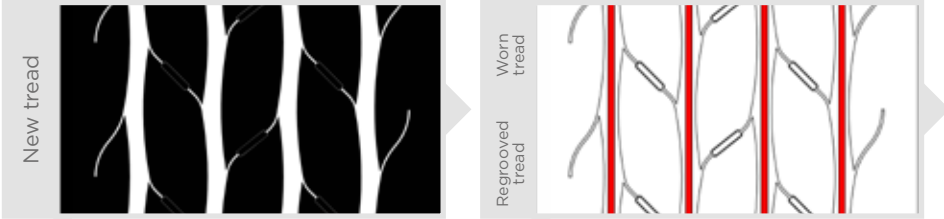

### SIZE RANGE (W. MAX: 8 mm)

SIZE	P MAX (mm)
385/55 R 22.5	3
385/65 R 22.5	3

## R02 PRO TRAILER 17.5 & 19.5

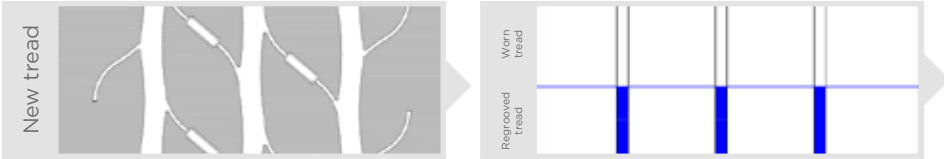

### SIZE RANGE 17.5' (W. MAX: 8 mm)

SIZE	P MAX (mm)
205/65 R 17.5	2
215/75 R 17.5	2
235/75 R 17.5	2
245/70 R 17.5	2

### SIZE RANGE 19.5' (W. MAX: 8 mm)

SIZE	P MAX (mm)
245/70 R 19.5	2
265/70 R 19.5	2
285/70 R 19.5	2

# REGROOVING DATA

## ITINERIS S

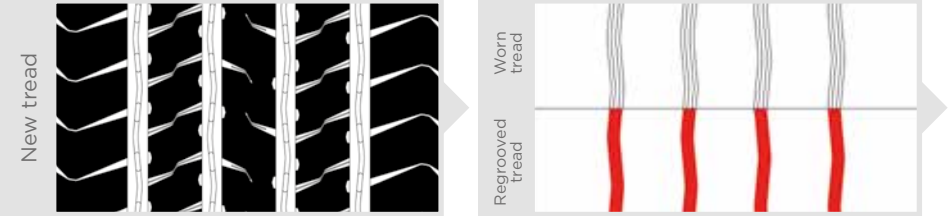

### SIZE RANGE (W. MAX: 8 mm)

SIZE	P MAX (mm)
315/70 R 22.5	2
295/80 R 22.5	2
315/80 R 22.5	2

## ITINERIS D

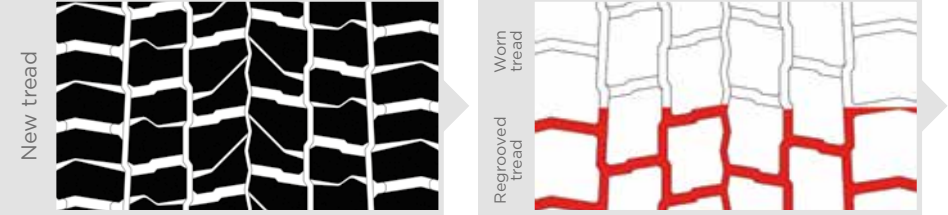

### SIZE RANGE (W. MAX: 8 mm)

SIZE	P MAX (mm)
315/70 R 22.5	2
295/80 R 22.5	2
315/80 R 22.5	2

## ITINERIS T

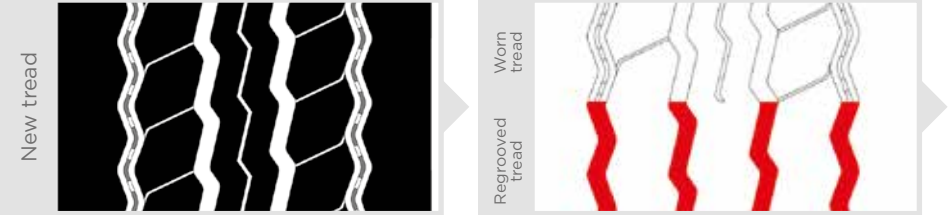

### SIZE RANGE (W. MAX: 8 mm)

SIZE	P MAX (mm)
385/55 R 22.5	3
385/65 R 22.5	3

# REGROOVING DATA

## FW:01

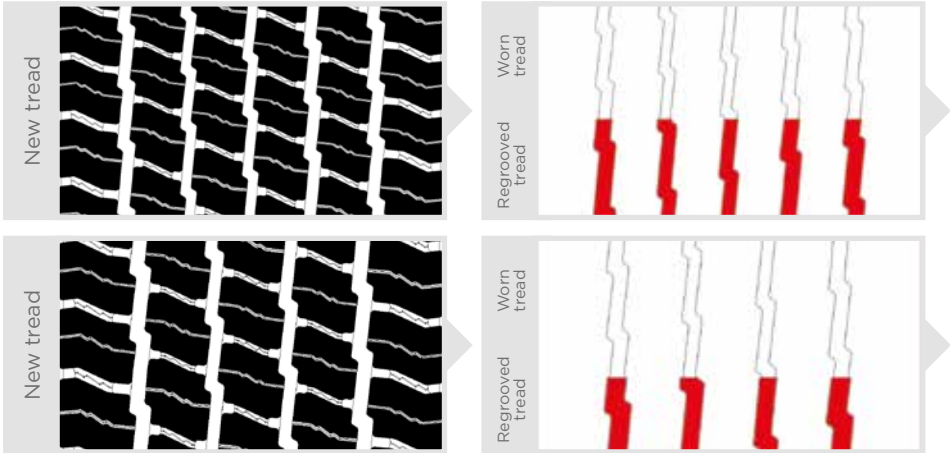

### SIZE RANGE (W. MAX: 8 mm)

SIZE	P MAX (mm)
385/55 R 22.5	2,5
385/65 R 22.5	3

SIZE	P MAX (mm)
315/70 R 22.5	3
295/80 R 22.5	3
315/80 R 22.5	3

## TW:01

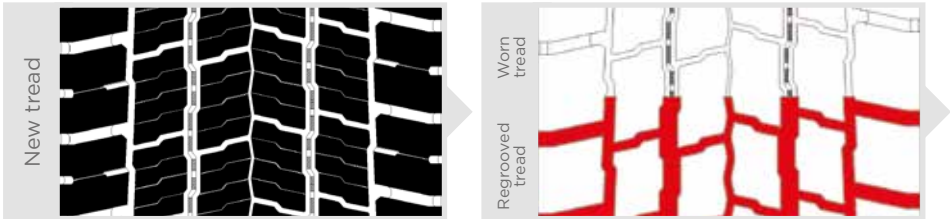

### SIZE RANGE (W. MAX: 8 mm)

SIZE	P MAX (mm)
295/80 R 22.5	3
315/70 R 22.5	3
315/80 R 22.5	3

# REGROOVING DATA

## C02 COACH MULTIAXLE

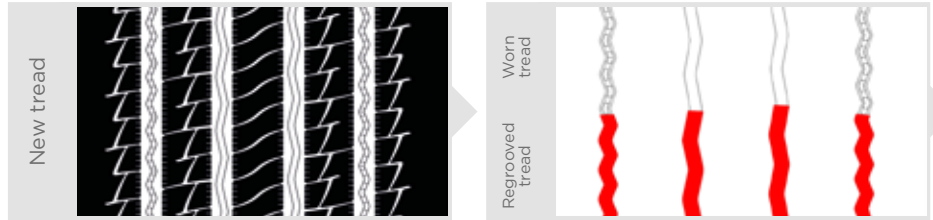

### SIZE RANGE (W. MAX: 8 mm)

SIZE	P MAX (mm)
295/80 R 22.5	3
315/80 R 22.5	3

## C02 COACH DRIVE

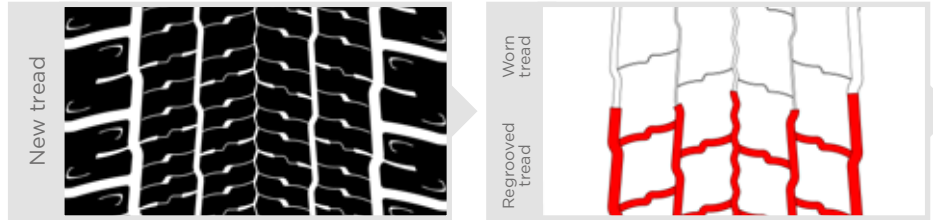

### SIZE RANGE (W. MAX: 8 mm)

SIZE	P MAX (mm)
295/80 R 22.5	3

## U02 URBAN-e MULTIAXLE

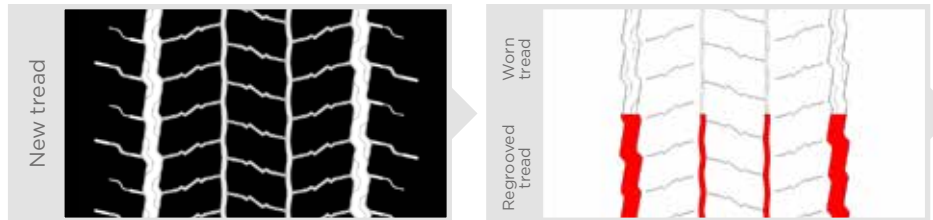

### SIZE RANGE (W. MAX: 8 mm)

SIZE	P MAX (mm)
315/60 R 22.5	3
275/70 R 22.5	3

## MC88 III M+S AMARANTO

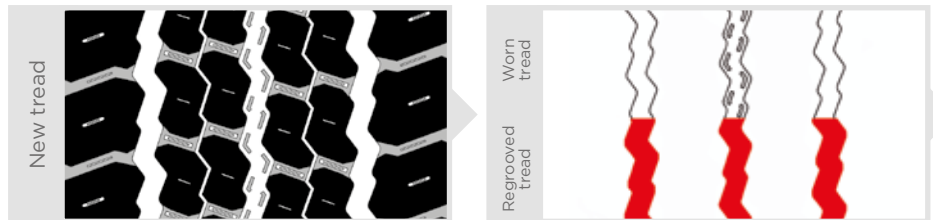

### SIZE RANGE (W. MAX: 8 mm)

SIZE	P MAX (mm)
275/70 R 22.5	2,5

# REGROOVING DATA

## G02 ECO MULTIAXLE

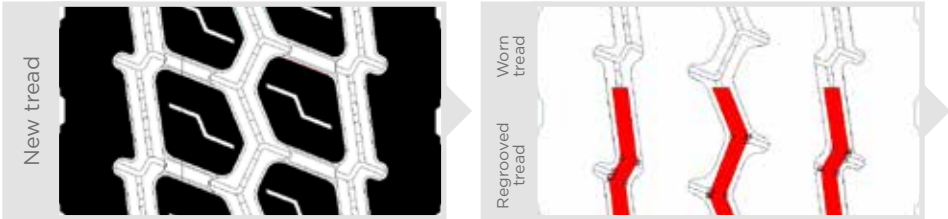

### SIZE RANGE (W. MAX: 8 mm)

SIZE	P MAX (mm)
13 R 22.5	3,5
295/80 R 22.5	3
315/80 R 22.5	3

## G02 ECO PRO DRIVE

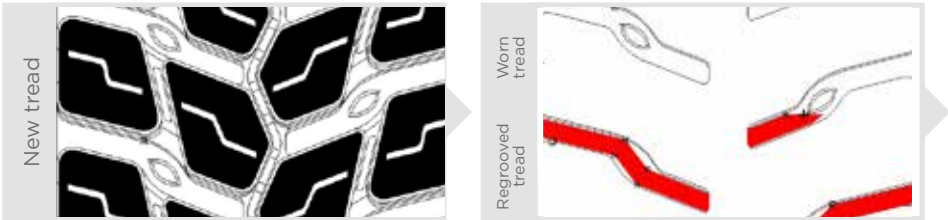

### SIZE RANGE (W. MAX: 8 mm)

SIZE	P MAX (mm)
13 R 22.5	3
295/80 R 22.5	3
315/80 R 22.5	3

## G02 PRO MULTIAXLE

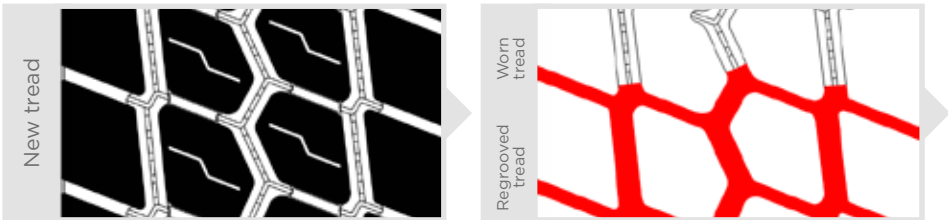

### SIZE RANGE (W. MAX: 8 mm)

SIZE	P MAX (mm)
385/65 R 22.5	3
425/65 R 22.5	3

# REGROOVING DATA

## FG:01 II

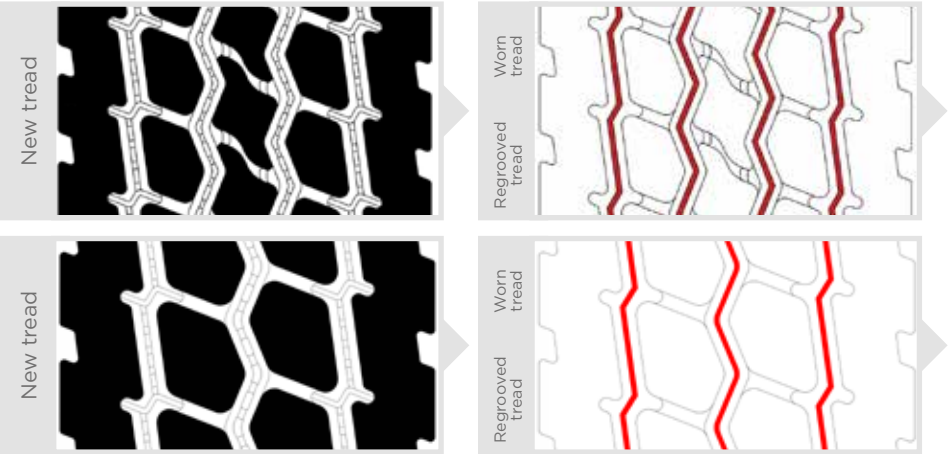

### SIZE RANGE (W. MAX: 8 mm)

SIZE	P MAX (mm)
315/80 R 22.5	3

SIZE	P MAX (mm)
13 R 22.5	3,5
295/80 R 22.5	3

## TG:01 II

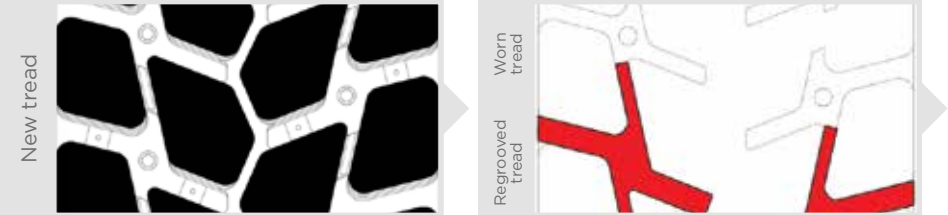

### SIZE RANGE (W. MAX: 8 mm)

SIZE	P MAX (mm)
13 R 22.5	3,5
315/80 R 22.5	3
295/80 R 22.5	3

# REGROOVING DATA

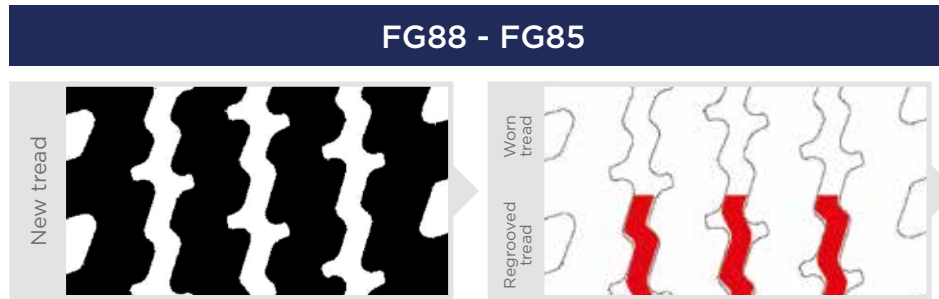

**SIZE RANGE  
(W. MAX: 8 mm)**

SIZE	P MAX (mm)
12.00 R 20 FG85	2,5
12.00 R 24 FG85	3
11 R 22.5 FG85	3
12 R 22.5 FG85	3
13 R 22.5 FG88	3,5
315/80 R 22.5 FG88	3



**SIZE RANGE  
(W. MAX: 8 mm)**

SIZE	P MAX (mm)
12.00 R 20 TG85	2,5
12.00 R 24 TG85	3
12 R 22.5 TG85	3
13 R 22.5 TG88	3,5
315/80 R 22.5 TG88	3

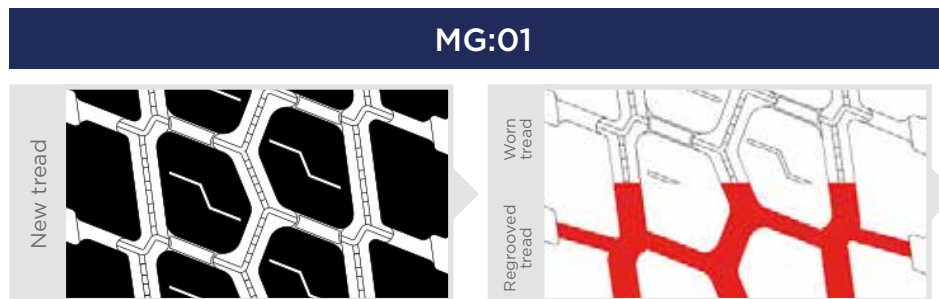

**SIZE RANGE  
(W. MAX: 8 mm)**

SIZE	P MAX (mm)
265/70 R 19.5	3,5

# REGROOVING DATA

## TQ:01 ROCK

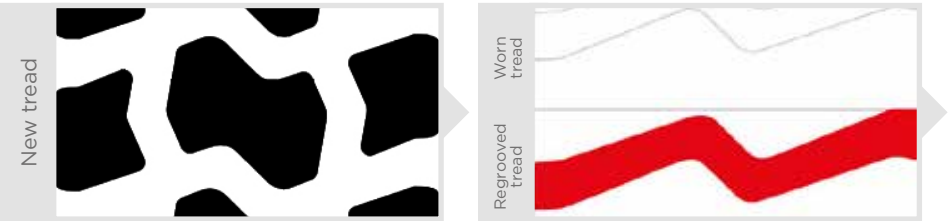

### SIZE RANGE (W. MAX: 8 mm)

SIZE	P MAX (mm)
13 R 22.5	3,5

## PS22 PISTA

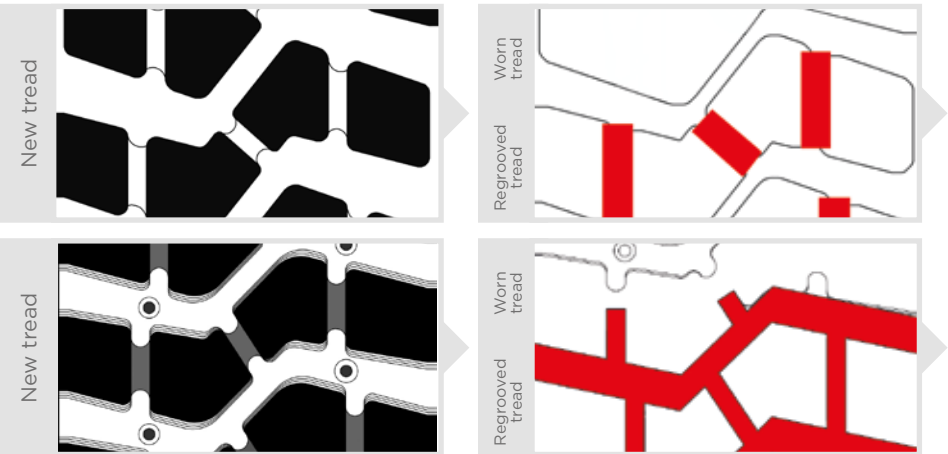

### SIZE RANGE (W. MAX: 8 mm)

SIZE	P MAX (mm)
14/00 R 20	3,5
335/80 R 20	3
365/80 R 20	3

SIZE	P MAX (mm)
365/85 R 20	3
395/85 R 20	3,5

# REGROOVING DATA

## S02 PISTA

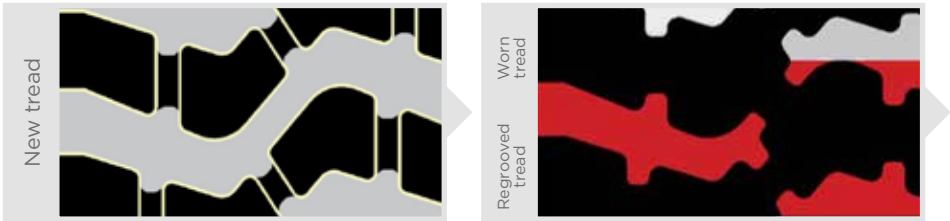

### SIZE RANGE (W. MAX: 8 mm)

SIZE	P MAX (mm)
14.00 R 20	3
335/80 R 20	3
365/80 R 20	3
365/85 R 20	3
395/85 R 20	3

## AP05

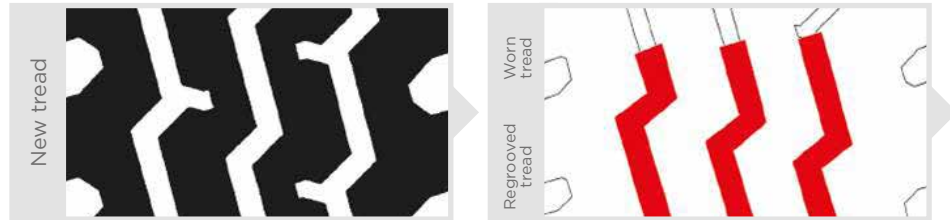

### SIZE RANGE (W. MAX: 8 mm)

SIZE	P MAX (mm)
11.00 R 20	2,5
12.00 R 20	2,5

# REGROOVING DATA

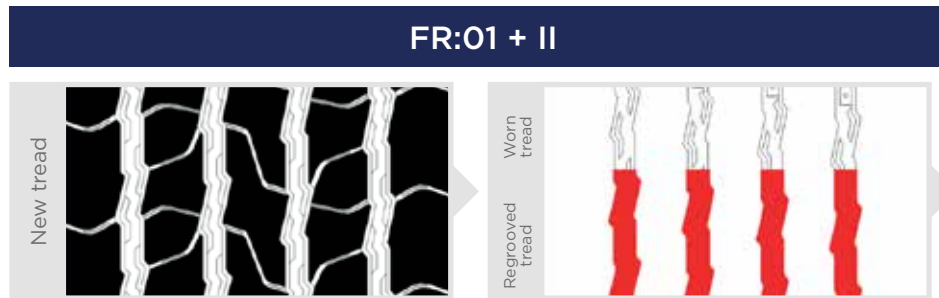

**SIZE RANGE**  
(W. MAX: 8 mm)

SIZE	P MAX (mm)
315/70 R 22.5	3
295/80 R 22.5	3
315/80 R 22.5	3

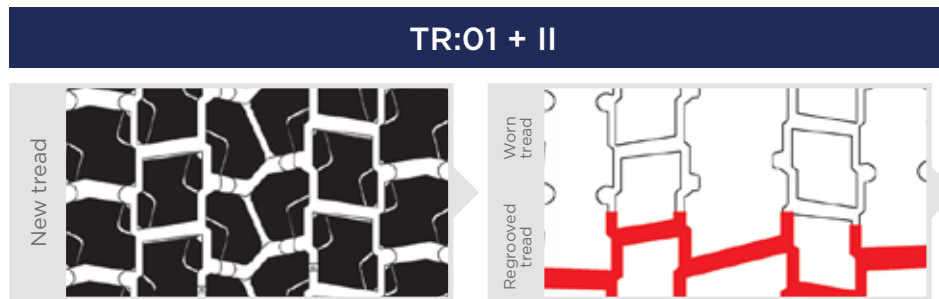

**SIZE RANGE**  
(W. MAX: 8 mm)

SIZE	P MAX (mm)
315/70 R 22.5	3
295/80 R 22.5	3
315/80 R 22.5	3

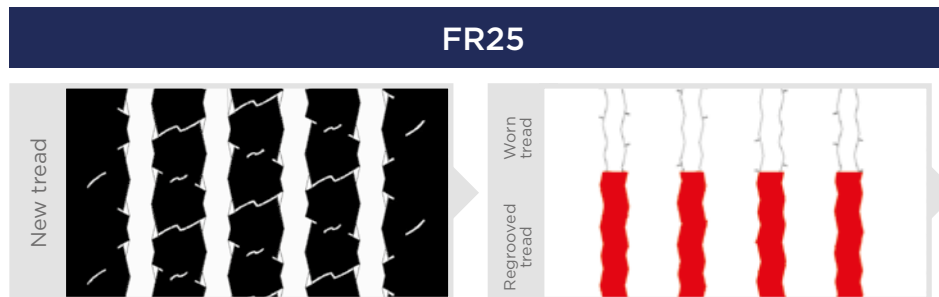

**SIZE RANGE**  
(W. MAX: 8 mm)

SIZE	P MAX (mm)
11 R 22.5	3
12 R 22.5	2,5
315/80 R 22.5	2,5
295/ 80 R 22.5	2,5

# REGROOVING DATA

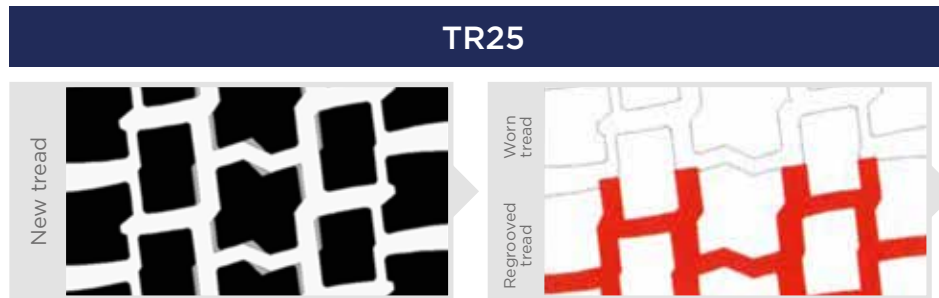

**SIZE RANGE**  
(W. MAX: 8 mm)

SIZE	P MAX (mm)
12 R 22.5	2,5
315/80 R 22.5	2,5

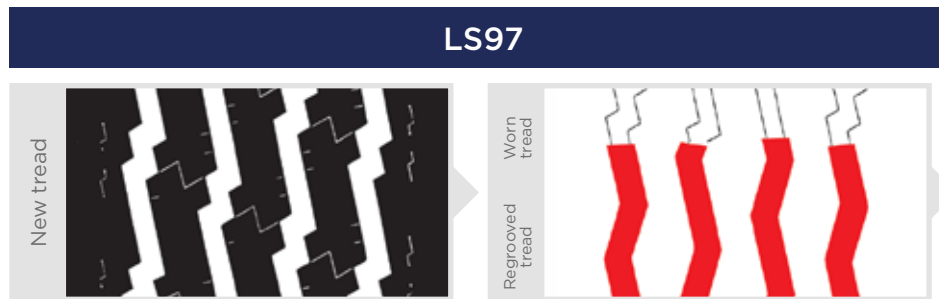

**SIZE RANGE**  
(W. MAX: 8 mm)

SIZE	P MAX (mm)
10 R 22.5	3
8.5 R 17.5	2
11.00 R 20	2,5

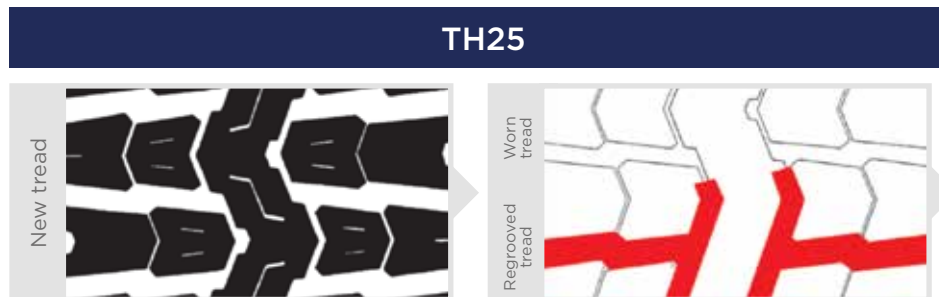

**SIZE RANGE**  
(W. MAX: 8 mm)

SIZE	P MAX (mm)
10 R 22.5	3

# REGROOVING DATA

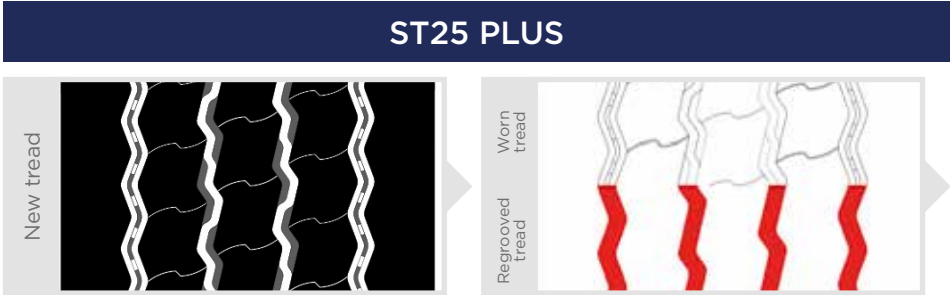

**SIZE RANGE**  
(W. MAX: 8 mm)

SIZE	P MAX (mm)
385/65 R 22.5	3



## ATTENTION!

The information contained in this manual relates to tyres designed exclusively for goods vehicles and/or passenger vehicles. Any other applications are not permitted.

INCORRECT OR IMPROPERLY USED TYRES CAN BE DANGEROUS. TYRES HAVE TO BE USED IN THE CORRECT SEGMENT OF APPLICATION, AS SPECIFIED FOR EACH PRODUCT IN THE TECHNICAL CATALOGUE.

The manual has been produced in an easily understood form for information purposes and is not intended to be comprehensive in nature. The data given will be updated periodically.

Since the manual is intended for international use the information may not reflect national legislative requirements which must be taken into consideration.

With regard to care and maintenance it is necessary to follow the tyre manufacturer's instructions. In particular, please remember that tyres age even if they have not been used or have only been used occasionally. Cracking of the tread and sidewall rubber, sometimes accompanied by carcass deformation, is evidence of ageing.

Old and aged tyres must be checked by a tyre specialist to ascertain their suitability for further use.

If in doubt concerning the interpretation of information please contact your local Prometeon representative.

THE PIRELLI LOGO, FH:01, TH:01, FR:01, TR:01, FG:01, TG:01, PS22, FW:01, TW:01, MC:01, MC88, FG88, TG88, APO5 ARE TRADEMARKS USED BY PROMETEON TYRE GROUP UNDER LICENSE.

**PROUD SPONSOR OF**

---



Discover more on [prometeon.com](https://www.prometeon.com)

**FOLLOW US**

---



**PROMETEON**  
TYRE. MADE FOR BUSINESS